

LETTING DATE 04-18-17  
 TWIN BOX  
 BROS-C024(113)--5F-24  
 RCB CULVERT REPLACEMENT ~ TWIN BOX  
 CRAWFORD COUNTY

### TRAFFIC CONTROL PLAN

THIS ROAD WILL BE CLOSED TO THROUGH TRAFFIC DURING CONSTRUCTION. LOCAL TRAFFIC TO ADJACENT PROPERTIES WILL BE MAINTAINED AS PROVIDED FOR IN ARTICLE 1107.08 OF THE CURRENT STANDARD SPECIFICATIONS. TRAFFIC CONTROL DEVICES, PROCEDURES, LAYOUTS, SIGNING, AND PAVEMENT MARKINGS INSTALLED WITHIN THE LIMITS OF THIS PROJECT SHALL CONFORM TO THE "MANUAL ON UNIFORM TRAFFIC CONTROL DEVICES FOR STREETS AND HIGHWAYS, AS ADOPTED BY THE DEPARTMENT PER 761 OF THE IOWA ADMINISTRATIVE CODE (IAC), CHAPTER 130."

### PERMITS

CONSTRUCT THIS PROJECT ACCORDING TO THE REQUIREMENTS OF U.S. ARMY CORPS OF ENGINEERS REGIONAL PERMIT 7, PERMIT NO. CEMVR-OD-P-2016-933. A COPY OF THIS PERMIT IS AVAILABLE FROM THE IOWA DOT WEBSITE (<http://www.enrpermits.iowadot.gov/>). THE U.S. ARMY CORPS OF ENGINEERS RESERVES THE RIGHT TO VISIT THE SITE WITHOUT PRIOR NOTICE.

THIS PROJECT IS COVERED BY THE IOWA DEPARTMENT OF NATURAL RESOURCES NPDES GENERAL PERMIT NO. 2. THE CONTRACTOR SHALL CARRY OUT THE TERMS AND CONDITIONS OF GENERAL PERMIT NO. 2 AND THE STORM WATER POLLUTION PREVENTION PLAN WHICH IS A PART OF THESE CONTRACT DOCUMENTS. REFER TO SECTION 2602 OF THE STANDARD SPECIFICATIONS FOR ADDITIONAL INFORMATION.

### DRAWING APPROVAL

ALL SHOP DRAWINGS THAT REQUIRE APPROVAL SHALL BE APPROVED BY THE CRAWFORD COUNTY ENGINEER.

ADDRESS: 1202 BROADWAY, P.O. BOX 458  
DENISON, IOWA 51442-0458

TELEPHONE: (712)263-2449

EMAIL: [possman@crawfordcounty.org](mailto:possman@crawfordcounty.org)

THESE SHOP DRAWINGS SHALL NOT BE SENT TO IOWA D.O.T. OFFICE OF BRIDGE DESIGN.



Highway Division

PLANS OF PROPOSED IMPROVEMENTS ON THE

# FARM-TO-MARKET SYSTEM CRAWFORD COUNTY

PROJECT NO. BROS-C024(113)--5F-24  
RCB CULVERT REPLACEMENT - TWIN BOX  
O AVENUE: FROM 120TH ST. TO 130TH ST.

SCALES: AS NOTED

REFER TO THE PROPOSAL FORM FOR LIST OF APPLICABLE SPECIFICATIONS.

TOTAL SHEETS	16
PROJECT NUMBER	BROS-C024(113)--5F-24
R.O.W. PROJECT NUMBER	
PROJECT IDENTIFICATION NUMBER	
FHWA STRUCTURE NO.	128290

### INDEX OF SHEETS

NO.	DESCRIPTION
A1	TITLE SHEET
C1	ESTIMATED PROJECT QUANTITIES
C1-3	ESTIMATED REFERENCE INFORMATION
C4	POLLUTION PREVENTION PLAN
C5	TABULATIONS
D1	PLAN AND PROFILE
G1	DETAILS OF REFERENCE INFORMATION
Q1	SOILS SHEET
U1	DETAIL SHEET
V1	SITUATION PLAN
V2	SUBDRAIN DETAILS
W1-2	CROSS SECTIONS -- ROADWAY
Z1-2	CROSS SECTIONS - CHANNEL

### STANDARD ROAD PLANS

STANDARD ROAD PLANS ARE LISTED ON PLAN SHEET C1.

### STANDARD BRIDGE PLANS

STANDARD BRIDGE PLANS ARE LISTED ON PLAN SHEET C1.

### UTILITY CONTACTS

FRONTIER COMMUNICATIONS  
Trent Flockhart  
Phone: 515-573-1268  
Email: [trent.flockhart@ftr.com](mailto:trent.flockhart@ftr.com)

WESTERN IOWA POWER COOPERATIVE  
Jason Lee  
Phone: 712-263-2943  
Email: [jason.lee@wipco.com](mailto:jason.lee@wipco.com)

### MILEAGE SUMMARY

LOCATION	LIN. FT.	MILES
BOP STA. 17+00 TO EOP STA. 24+00	700.00	
NET LENGTH OF ROADWAY	700.00	0.133

Approved

*[Signature]* 11/24/17  
CRAWFORD COUNTY ENGINEER DATE

I HEREBY CERTIFY THAT THIS ENGINEERING DOCUMENT WAS PREPARED BY ME OR UNDER MY DIRECT PERSONAL SUPERVISION AND THAT I AM A DULY LICENSED PROFESSIONAL ENGINEER UNDER THE LAWS OF THE STATE OF IOWA.

*[Signature]* 01/18/2017  
TROY J. GROTH, P.E. #14450 DATE

MY LICENSE RENEWAL DATE IS DECEMBER 31, 2017.

PAGES OR SHEETS COVERED BY THIS SEAL: ALL EXCEPT Q1

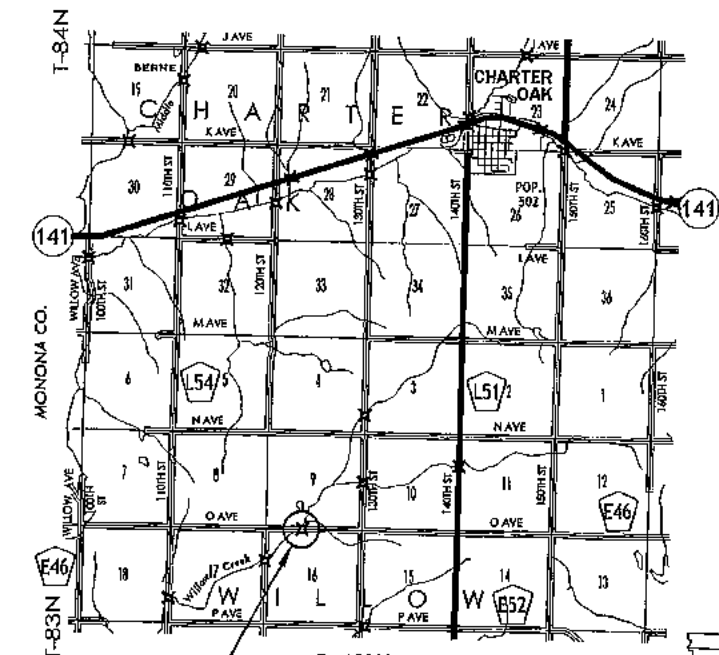
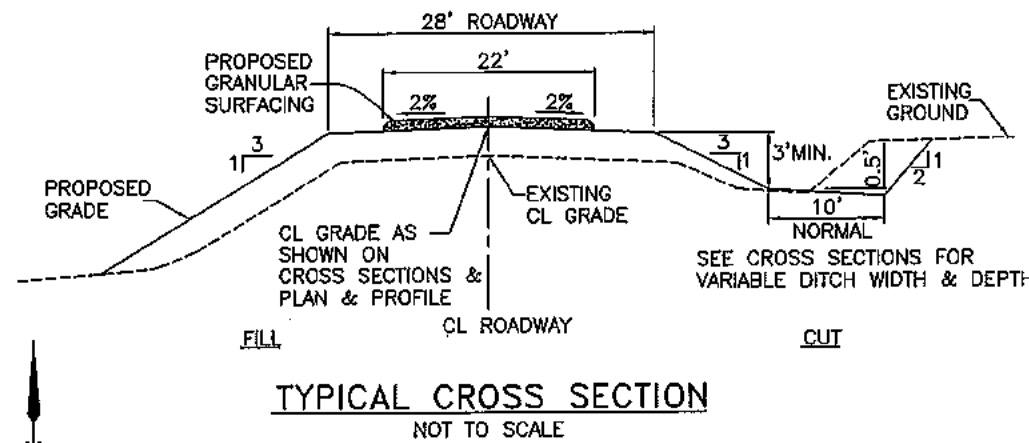

STA. 20+30  
PROPOSED TWIN 12'x12'x54' RCB CULVERT  
45° SKEW LT. AHEAD  
B.O.P. STA. 17+00  
E.O.P. STA. 24+00

**SUNDQUIST ENGINEERING, P.C.**  
120 S. MAIN, P.O. BOX 220, DENISON, IOWA 51442  
PHONE: (712)263-8118 FAX: (712)263-2181  
[www.sundquistengineering.com](http://www.sundquistengineering.com)

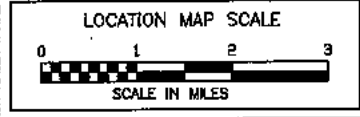

**IOWA ONE CALL**  
CALL BEFORE YOU DIG!  
1-800-292-8989  
[www.iowaonecall.com](http://www.iowaonecall.com)

04-30-02 101-4

### DESIGN DATA RURAL

2012 AADT	40	V.P.D.
2037 AADT	60	V.P.D.
201X DHV	X	V.P.H.
TRUCKS	10	%
TOTAL DESIGN ESALs		

### INDEX OF SEALS

SHEET NO.	NAME	TYPE
A1	TROY J. GROTH	PRIMARY SIGNATURE BLOCK
Q1	JAMES A. BERTSCH	GEOTECHNICAL DESIGN

Approved

*[Signatures]*

BOARD OF SUPERVISORS

ESTIMATED PROJECT QUANTITIES

100-1A  
07-15-97

ITEM NO.	ITEM CODE	ITEM	UNIT	TOTAL	AS BUILT QTY.
1	2101-0850002	CLEARING AND GRUBBING	UNIT	138	
2	2102-0425071	SPECIAL BACKFILL	CY	84.8	
3	2102-2710070	EXCAVATION, CLASS 10, ROADWAY AND BORROW	CY	3298.5	
4	2104-2710020	EXCAVATION, CLASS 10, CHANNEL	CY	5194.5	
5	2107-0425020	COMPACTING BACKFILL ADJACENT TO BRIDGES, CULVERTS OR STRUCTURES	CY	96.0	
6	2113-0001100	SUBGRADE STABILIZATION MATERIAL, POLYMER GRID	SY	472.1	
7	2312-8260051	GRANULAR SURFACING ON ROAD, CLASS A CRUSHED STONE	TON	308.9	
8	2401-6745625	REMOVAL OF EXISTING BRIDGE	LS	1.00	
9	2402-2720000	EXCAVATION, CLASS 20	CY	2320	
10	2402-2725005	FOUNDATION TREATMENT MATERIAL	TON	284.733	
11	2403-0100020	STRUCTURAL CONCRETE (RCB CULVERT)	CY	446.2	
12	2404-7775000	REINFORCING STEEL	LB	61339	
13	2417-0225048	APRONS, METAL, 48 IN. DIA.	EACH	1	
14	2501-5775000	PILES, STEEL SHEET	SF	880	
15	2502-8215148	SUBDRAIN, CORRUGATED METAL PIPE, 48 IN. DIA.	LF	30	
16	2507-3250005	ENGINEERING FABRIC	SY	1287.2	
17	2507-6800021	REVEITEMENT, CLASS B	TON	180.7	
18	2507-6875002	REVEITEMENT, REMOVE AND REPLACE	CY	34.6	
19	2518-6910000	SAFETY CLOSURE	EACH	2	
20	2526-8285000	CONSTRUCTION SURVEY	LS	1.00	
21	2528-8445110	TRAFFIC CONTROL	LS	1.00	
22	2533-4980005	MOBILIZATION	LS	1.00	
23	2601-2640350	SPECIAL DITCH CONTROL, WOOD EXCELSIOR MAT	SQ	17.9	
24	2602-0000020	SILT FENCE	LF	582.5	
25	2602-0000030	SILT FENCE FOR DITCH CHECKS	LF	120.0	
26	2602-0010010	MOBILIZATIONS, EROSION CONTROL	EACH	1	

ESTIMATE REFERENCE INFORMATION

100-4A  
10-29-02

Item No.	Item Code	Description
1	2101-0850001	CLEARING AND GRUBBING REFER TO TAB. 110-17. INCLUDES CLEARING AND GRUBBING WITHIN THE LIMITS OF THE RIGHT-OF-WAY AND TEMPORARY EASEMENTS SHOWN ON PLAN SHEET V1.
2	2102-0425071	SPECIAL BACKFILL REFER TO DETAILS ON PLAN SHEET U1. AGGREGATE TYPE SHALL BE CRUSHED LIMESTONE OR CRUSHED P.C.C. NO GRAVEL OR RAP WILL BE ALLOWED.
3	2102-2710070	EXCAVATION, CLASS 10, ROADWAY AND BORROW INCLUDES 1578.7 C.Y. CUT, 3298.5 C.Y. FILL +35% SHRINK, AND 1719.8 C.Y. BORROW. REFER TO TABULATION OF EARTHWORK QUANTITIES ON PLAN SHEET C5. TYPE A COMPACTION WILL BE REQUIRED. BORROW MAY BE OBTAINED FROM SUITABLE CLASS 20 AND CLASS 10 CHANNEL EXCAVATION. CONTRACTOR SHALL PROVIDE ADDITIONAL NECESSARY BORROW. NO PAYMENT FOR OVERHAUL WILL BE ALLOWED.  EXISTING SLOPES THAT ARE TO RECEIVE EMBANKMENT, REGARDLESS OF THEIR HEIGHT, SHALL BE PREPARED IN ACCORDANCE WITH ARTICLE 2107.03, C, 2, OF THE STANDARD SPECIFICATIONS.  A SUFFICIENT VOLUME OF SOIL HIGH IN ORGANIC CONTENT IS AVAILABLE WITHIN THE EXCAVATION LIMITS OF THE PROJECT. THIS MATERIAL SHALL BE DEPOSITED AS THE FINAL LAYER TO A MINIMUM FINISHED DEPTH OF 4 INCHES ON THE PROPOSED ROADWAY FORESLOPES AND OTHER DISTURBED AREAS TO FACILITATE ESTABLISHMENT OF PERMANENT VEGETATIVE COVER. THIS WORK SHALL BE CONSIDERED INCIDENTAL TO THIS BID ITEM.  PAYMENT FOR THIS ITEM WILL BE AT PLAN QUANTITY. CROSS SECTIONS WILL NOT BE TAKEN AFTER EXCAVATION FOR THE PURPOSE OF DETERMINING ACTUAL QUANTITIES.
4	2104-2710020	EXCAVATION, CLASS 10, CHANNEL INCLUDES 5194.5 C.Y. CUT, 0 C.Y. FILL + 35% SHRINK, AND 5194.5 C.Y. WASTE. EXCESS MATERIAL AND UNSUITABLE MATERIAL NOT DESIRABLE TO BE INCORPORATED INTO THE WORK INVOLVED ON THIS PROJECT SHALL BECOME THE PROPERTY OF THE CONTRACTOR AND SHALL BE HAULED FROM THE SITE. THE COST OF HAULING AND DISPOSING OF THIS MATERIAL SHALL BE INCLUDED IN AND CONSIDERED INCIDENTAL TO THE PRICE BID FOR CLASS 10 CHANNEL EXCAVATION. NO PAYMENT FOR OVERHAUL WILL BE ALLOWED.  QUANTITY INCLUDES EXCAVATION REQUIRED TO INSTALL REVEITEMENT. QUANTITY INCLUDES EXCAVATION REQUIRED TO TRANSITION PROPOSED CHANNEL SLOPES INTO EXISTING SLOPES WITHIN THE LIMITS SHOWN ON PLAN SHEET V1.  PAYMENT FOR THIS ITEM WILL BE AT PLAN QUANTITY. CROSS SECTIONS WILL NOT BE TAKEN AFTER EXCAVATION FOR THE PURPOSE OF DETERMINING ACTUAL QUANTITIES.
6	2113-0001100	SURGRADE STABILIZATION MATERIAL, POLYMER GRID REFER TO DETAILS ON PLAN SHEET U1.
7	2312-8260051	GRANULAR SURFACING ON ROAD, CLASS A CRUSHED STONE MATERIAL SHALL BE SPREAD BY THE CONTRACTOR AND THE CONTRACT UNIT PRICE PER TON SHALL INCLUDE THE COST OF SPREADING GRANULAR SURFACING ON ROADWAY SURFACE. RATE OF APPLICATION SHALL BE 2330 TONS PER MILE.
8	2401-6745625	REMOVAL OF EXISTING BRIDGE CONTRACTOR SHALL COORDINATE WITH COUNTY FOR REMOVAL OF TIMBER DECKING PLANK AND STEEL BEAMS. THESE MATERIALS SHALL BE REMOVED BY COUNTY FORCES AND REMAIN THE PROPERTY OF THE COUNTY. THE REMAINDER OF THE STRUCTURE SHALL BE REMOVED AND DISPOSED OF BY THE CONTRACTOR.
9	2402-2720000	EXCAVATION, CLASS 20 EXCAVATION TO THE LIMITS DETAILED ON PLAN SHEET U1 IS FOR PAY QUANTITIES ONLY. QUANTITY WAS CALCULATED FROM CURTAIN WALL TO CURTAIN WALL AND INCLUDES EXCAVATION AS DETAILED ON TWIN CULVERT STANDARD TWH 45-5-12. EXCESS MATERIAL AND UNSUITABLE SOILS SHALL BE HAULED FROM THE SITE AND DISPOSED OF BY THE CONTRACTOR. THE COST OF HAULING AND DISPOSING OF THIS MATERIAL SHALL BE INCLUDED IN AND CONSIDERED INCIDENTAL TO THE PRICE BID FOR CLASS 20 EXCAVATION.  PRIOR TO CONSTRUCTION OF THE RCB CULVERT, BACKFILL OF THE CLASS 20 EXCAVATION WITH FOUNDATION TREATMENT MATERIAL AND SPECIAL BACKFILL SHALL BE COMPLETED THROUGHOUT THE ENTIRE CROSS SECTION TO AN ELEVATION AT OR ABOVE THE BOTTOM OF THE CULVERT FLOOR.
10	2402-2725005	FOUNDATION TREATMENT MATERIAL REFER TO DETAILS ON PLAN SHEET U1. USE AGGREGATE THAT MEETS THE REQUIREMENTS OF SECTION 4122 FOR MACADAM STONE BASE. REMOVAL OF UNSUITABLE OR UNSTABLE SOIL AND PLACEMENT OF FOUNDATION TREATMENT MATERIAL SHALL BE IN ACCORDANCE WITH ARTICLE 2402.03, C, 3, OF THE STANDARD SPECIFICATIONS.  MATERIAL ORDERED PLACED BY THE ENGINEER WILL BE MEASURED IN TONS TO THE NEAREST 0.1 TONS. PAYMENT WILL BE AT THE CONTRACT UNIT PRICE PER TON. NO ADJUSTMENT IN UNIT PRICE WILL BE ALLOWED FOR DEVIATION BETWEEN PLAN QUANTITY AND ACTUAL QUANTITY PLACED.
11	2403-0100020	STRUCTURAL CONCRETE (RCB CULVERT) REFER TO TABULATION ON PLAN SHEET C5 FOR CONCRETE PLACEMENT QUANTITIES. ITEM INCLUDES CERTIFIED PLANT INSPECTION IN ACCORDANCE WITH SECTION 2521 OF THE STANDARD SPECIFICATIONS.

STANDARD ROAD PLANS

105-4  
10-18-11

The following Standard Road Plans apply to construction work on this project.

NUMBER	DATE	TITLE
DR-101	04-18-17	PIPE CULVERT (BEDDING AND BACKFILL)
DR-104	04-19-16	DEPTH OF COVER TABLES FOR CONCRETE AND CORRUGATED PIPE
DR-122	10-18-16	CONSTRUCTION OF TYPE 'C' CONCRETE ADAPTERS FOR PIPE CULVERT CONNECTIONS
DR-203	04-21-15	METAL PIPE APRONS AND BEVELED ENDS
DR-501	04-21-15	CORRUGATED METAL TYPE "A" DIAPHRAGM
EC-101	04-19-16	SPECIAL DITCH CONTROL
EC-201	10-18-16	SILT FENCE
EW-101	04-18-17	EMBANKMENT AND REBUILDING EMBANKMENTS
EW-110	10-20-15	DITCH BLOCKS AND DIKES
TC-1	04-16-13	WORK NOT AFFECTING TRAFFIC (TWO-LANE, OR MULTI-LANE)
TC-252	04-19-16	ROUTES CLOSED TO TRAFFIC

STANDARD BRIDGE PLANS

STANDARD	ISSUED	REVISED
TWRCB G1-12	APRIL, 2012	07-16
TWRCB G2-12	APRIL, 2012	12-16
TWRCB 12-12-12	APRIL, 2012	
TWH 45-1-12	APRIL, 2012	12-16
TWH 45-2-12	APRIL, 2012	12-16
TWH 45-3-12	APRIL, 2012	
TWH 45-4-12	APRIL, 2012	
TWH 45-5-12	APRIL, 2012	12-16
TWH 45-6-12	APRIL, 2012	07-16
TWH 45-7-12	APRIL, 2012	
PRCB G1-13	JANUARY, 2013	07-16
PRCB G2-13	JANUARY, 2013	07-16
PRCB 12-13	JANUARY, 2013	
PES 2-13-T3	JANUARY, 2013	07-16
PES 3-13-T3	JANUARY, 2013	07-16
PES 4-13	JANUARY, 2013	
PEP 1-13	JANUARY, 2013	12-15

INDEX OF TABULATIONS

111-25  
10-18-11

Tabulation	Tabulation Title	Sheet No.
100-1A	ESTIMATED PROJECT QUANTITIES	C1
100-4A	ESTIMATE REFERENCE INFORMATION	C1-2
100-17	TABULATION OF SILT FENCES	C5
100-18	TABULATION OF SILT FENCES FOR DITCH CHECKS	C5
100-22	ROLLED EROSION CONTROL	C5
105-4	STANDARD ROAD PLANS	C1
108-13A	SAFETY CLOSURES	C5
110-12A	POLLUTION PREVENTION PLAN	C4
110-17	CLEARING AND GRUBBING	C5
111-25	INDEX OF TABULATIONS	C1
	TABULATION OF EARTHWORK QUANTITIES	C5
	PLACEMENT OF QUANTITIES	C5

## ESTIMATE REFERENCE INFORMATION

100-4A  
10-29-02

Item No.	Item Code	Description
12	2404-7775000	<u>REINFORCING STEEL</u> REFER TO TABULATION ON PLAN SHEET C5 FOR STEEL PLACEMENT QUANTITIES. NO QUANTITY ADJUSTMENT WILL BE MADE DUE TO SUBDRAIN OUTLET THRU INLET HEADWALL WING.
13	2417-0225042	<u>APRONS, METAL, 48 IN. DIA.</u> FABRICATE FROM SAME GAGE METAL AS CULVERT PIPE.
14	2501-577500	<u>PILES, STEEL SHEET</u> SHALL BE 5 GAGE STEEL SHEETING WITH A MINIMUM SECTION MODULUS OF 3.3 CUBIC INCHES PER FOOT. REFER TO DETAILS ON PLAN SHEET U1.
15	2502-8215142	<u>SUBDRAIN, CORRUGATED METAL PIPE, 48 IN. DIA.</u> REFER TO DETAILS ON PLAN SHEET V2. ALL CORRUGATED METAL PIPE LARGER THAN 12 INCHES IN DIAMETER SHALL BE ANNULAR, RIVETED PIPE. HELICAL PIPE WILL NOT BE ALLOWED FOR PIPE DIAMETERS LARGER THAN 12 INCHES. ALL BANDS SHALL BE 24-INCH WIDE BANDS.  THE METAL SHEET THICKNESS USED TO FABRICATE CORRUGATED METAL PIPES LARGER THAN 12 INCHES IN DIAMETER SHALL BE INCREASED BY ONE GAGE THICKNESS ABOVE THAT REQUIRED BY STANDARD ROAD PLAN DR-104. ALL CORRUGATED METAL PIPES 36 INCHES IN DIAMETER OR GREATER SHALL BE FURNISHED WITH 3 IN. X 1 IN. CORRUGATIONS.  USE CLASS 'C' BEDDING & BACKFILL PER STANDARD ROAD PLAN DR-101. BACKFILL WITH SOIL. CONSTRUCT CONCRETE COLLAR WITH MINIMUM WIDTH OF 12 INCHES AND MINIMUM THICKNESS OF 4 INCHES. REFER TO STANDARD ROAD PLAN DR-122 FOR DETAILS OF COLLAR REINFORCING.
16	2507-3250005	<u>ENGINEERING FABRIC</u> ITEM INCLUDES 1030.0 S.Y. OF ENGINEERING FABRIC PLACED ON THE BOTTOM, TOP, ENDS AND SIDES OF THE FOUNDATION TREATMENT MATERIAL. REFER TO DETAILS ON PLAN SHEET U1. ENGINEERING FABRIC FOR THIS PURPOSE SHALL BE MIRAFI 500X, GEOTEX 200ST, CONTECH C200, OR APPROVED EQUAL.  ITEM INCLUDES 257.2 S.Y. OF ENGINEERING FABRIC PLACED ON THE BOTTOM, ENDS AND SIDES OF CLASS B REVETMENT. REFER TO DETAILS ON PLAN SHEET U1. ENGINEERING FABRIC FOR THIS PURPOSE SHALL BE MATERIAL AS SPECIFIED FOR EMBANKMENT EROSION CONTROL IN ACCORDANCE WITH ARTICLE 4196.01, B, 3, OF THE STANDARD SPECIFICATIONS.  MATERIAL SHALL BE JOINED BY OVERLAPPING A MINIMUM OF 18 INCHES. THE QUANTITY OF ENGINEERING FABRIC FOR WHICH PAYMENT WILL BE MADE, WHEN PLACED AS DETAILED IN THE CONTRACT DOCUMENTS, WILL BE THE QUANTITY SHOWN IN THE CONTRACT DOCUMENTS IN SQUARE YARDS. MATERIAL FOR LAPS IS NOT INCLUDED IN THE PLAN QUANTITY.
17	2507-6800021	<u>REVETMENT, CLASS B</u> THIS ITEM SHALL CONSIST OF FURNISHING AND PLACING REVETMENT STONE, COMPLETE IN PLACE AS SHOWN ON THE DRAWINGS. REFER TO DETAILS ON PLAN SHEET U1.  DEWATERING REQUIRED TO INSTALL REVETMENT SHALL BE INCLUDED IN AND CONSIDERED INCIDENTAL TO THE PRICE BID FOR THIS ITEM.  THE CONTRACTOR WILL BE RESPONSIBLE FOR REMOVAL OF ALL REMNANTS OF REVETMENT STOCKPILES FROM FARM FIELDS UTILIZED BY CONTRACTOR IN THE PROJECT AREA. THIS WORK SHALL BE INCLUDED IN AND CONSIDERED INCIDENTAL TO THE PRICE BID FOR THIS ITEM.
18	2507-6875002	<u>REVETMENT, REMOVE AND REPLACE</u> ITEM INCLUDES REMOVING EXISTING CHANNEL BANK REVETMENT TO THE EXTENT NECESSARY TO COMPLETE INSTALLATION OF THE PROPOSED IMPROVEMENTS AND IN ACCORDANCE WITH DETAILS SHOWN IN THE PLANS. REVETMENT SHALL BE STOCKPILED AND REPLACED IN LOCATIONS SHOWN ON PLAN SHEET V1. REMOVAL AND DISPOSAL OF EXISTING ENGINEERING FABRIC, IF PRESENT, SHALL BE CONSIDERED INCIDENTAL TO THIS ITEM.  ANY PIECE GREATER THAN 3 FEET IN ANY DIMENSION SHALL BE PROCESSED SUCH THAT ITS SIZE IS REDUCED TO LESS THAN 3 FEET IN ALL DIMENSIONS. ANY REINFORCING STEEL SHALL BE CUT OFF FLUSH OR REMOVED. HMA MATERIAL SHALL NOT BE PLACED WITHIN THE FLOOD PLAN.  THE QUANTITY OF REVETMENT, REMOVE AND REPLACE FOR WHICH PAYMENT WILL BE MADE, WHEN PLACED AS SHOWN IN THE CONTRACT DOCUMENTS, WILL BE THE QUANTITY SHOWN IN THE CONTRACT DOCUMENTS IN CUBIC YARDS.  FOR REVETMENT, REMOVE AND REPLACE THE CONTRACTOR WILL BE PAID THE CONTRACT UNIT PRICE PER CUBIC YARD. THIS PAYMENT SHALL BE FULL COMPENSATION FOR FURNISHING ALL MATERIAL, EQUIPMENT AND LABOR AND FOR PERFORMANCE OF ALL WORK NECESSARY FOR REMOVING AND STOCKPILING THE EXISTING REVETMENT AND REPLACEMENT OF THE REVETMENT.
19	2518-6910000	<u>SAFETY CLOSURE</u> REFER TO TAB. 108-13A.
23	2601-2640350	<u>SPECIAL DITCH CONTROL, WOOD EXCELSIOR MAT</u> REFER TO TAB. 100-22 AND DETAILS ON PLAN SHEET C5. APPLY SLOPE PROTECTION IN THE DIRECTION OF THE FLOW OF WATER. ITEM INCLUDES ANY NECESSARY SHAPING OF AREA TO RECEIVE SLOPE PROTECTION. WATERING WILL NOT BE REQUIRED.  SEEDING, FERTILIZING, AND MULCHING WILL BE PERFORMED BY THE COUNTY. CONTRACTOR SHALL COORDINATE INSTALLATION OF THE WOOD EXCELSIOR MAT WITH THE COUNTY.

## ESTIMATE REFERENCE INFORMATION

100-4A  
10-29-02

Item No.	Item Code	Description
24	2602-0000020	<u>SILT FENCE</u> REFER TO TAB. 100-17. THE TABULATION INCLUDES ESTIMATED LOCATIONS FOR PLACEMENT OF SILT FENCE TO ADDRESS POSSIBLE EROSION DURING CONSTRUCTION. VERIFY THE SPECIFIC LOCATIONS WITH THE ENGINEER PRIOR TO BEGINNING PLACEMENT. BID ITEM INCLUDES 25% ADDITIONAL QUANTITY FOR FIELD ADJUSTMENT AND REPLACEMENTS.
25	2602-0000030	<u>SILT FENCE FOR DITCH CHECKS</u> REFER TO TAB. 100-18. THE TABULATION INCLUDES ESTIMATED LOCATIONS FOR PLACEMENT OF 'SILT FENCE FOR DITCH CHECKS' TO ADDRESS EROSION TO BE ENCOUNTERED DURING CONSTRUCTION. VERIFY THE SPECIFIC LOCATIONS WITH THE ENGINEER PRIOR TO BEGINNING PLACEMENT. BID ITEM INCLUDES 50% ADDITIONAL QUANTITY FOR FIELD ADJUSTMENTS AND REPLACEMENTS.

## GENERAL NOTES

IT SHALL BE THE CONTRACTOR'S RESPONSIBILITY TO MAKE ALL NECESSARY ARRANGEMENTS WITH ADJACENT PROPERTY OCCUPANTS FOR RESTRAINING LIVESTOCK FROM ENTERING THE RIGHT-OF-WAY DURING CONSTRUCTION.

CONTRACTOR IS TO USE DUE CAUTION IN WORKING OVER AND AROUND ALL TILE LINES. BREAKS IN THE TILE LINE DUE TO THE CONTRACTOR'S CARELESSNESS ARE TO BE REPLACED AT CONTRACTOR'S EXPENSE WITHOUT COST TO THE CONTRACTING AUTHORITY. ANY TILE LINES BROKEN OR DISTURBED BY CUT LINES WILL BE REPLACED AS DIRECTED BY THE ENGINEER IN CHARGE OF CONSTRUCTION AND AT THE CONTRACTING AUTHORITY'S EXPENSE.

WHERE PUBLIC UTILITY FIXTURES ARE SHOWN AS EXISTING ON THE PLANS OR ENCOUNTERED WITHIN THE CONSTRUCTION AREA, IT SHALL BE THE RESPONSIBILITY OF THE CONTRACTOR TO NOTIFY THE OWNERS OF THOSE UTILITIES PRIOR TO THE BEGINNING OF ANY CONSTRUCTION. THE CONTRACTOR SHALL AFFORD ACCESS TO THESE FACILITIES FOR NECESSARY MODIFICATION OF SERVICES. UNDERGROUND FACILITIES, STRUCTURES AND UTILITIES HAVE BEEN PLOTTED FROM AVAILABLE SURVEYS AND RECORDS, AND THEREFORE THEIR LOCATIONS MUST BE CONSIDERED APPROXIMATE ONLY. IT IS POSSIBLE THERE MAY BE OTHERS, THE EXISTENCE OF WHICH IS PRESENTLY NOT KNOWN OR SHOWN. IT IS THE CONTRACTOR'S RESPONSIBILITY TO DETERMINE THEIR EXISTENCE AND EXACT LOCATION AND TO AVOID DAMAGE THERETO. NO CLAIMS FOR ADDITIONAL COMPENSATION WILL BE ALLOWED TO THE CONTRACTOR FOR ANY INTERFERENCE OR DELAY CAUSED BY SUCH WORK.

CONTRACTOR SHALL NOTIFY ONE-CALL (1-800-292-8989) FOR UTILITY LOCATES PRIOR TO COMMENCING WORK.

SEEDING WILL BE ACCOMPLISHED BY THE COUNTY.

ALL STOCKPILE AREAS, HAUL ROADS, AND AREAS USED FOR EQUIPMENT ON THIS PROJECT REQUIRE SUBSOIL TILLAGE TO AN AVERAGE DEPTH OF 16 TO 20 INCHES PRIOR TO PLACEMENT OF TOPSOIL AND/OR STABILIZING CROP SEEDING. COMPLETE THIS TILLAGE AT 3 FOOT MAXIMUM CENTERS AND AT RIGHT ANGLES TO THE FINISHED SLOPE.

USE TILLAGE EQUIPMENT EQUIPPED WITH AN ARROWHEAD TYPE SHOE THAT WILL PROVIDE LATERAL DISPLACEMENT AND LIMIT THE MOVEMENT OF THE SUBSOIL TO THE SURFACE. OBTAIN THE ENGINEER'S APPROVAL FOR THE EQUIPMENT. THIS WORK IS INCIDENTAL TO OTHER WORK ON THE PROJECT.

FOLLOWING THE SUBSOIL TILLAGE, THE AREA IS TO REMAIN IN A "LOOSENEED" CONDITION. ADDITIONAL COMPACTION OR THE OPERATION OF HEAVY EQUIPMENT, OTHER THAN REQUIRED FOR TOPSOIL PLACEMENT AND SHAPING, WILL NOT BE ALLOWED ON AREAS WHICH HAVE BEEN RECEIVED SUBSOIL TILLAGE.

10-21-14 232-10  
DISPOSE OF ALL WOOD MATERIAL GENERATED AS A RESULT OF CLEARING AND/OR GRUBBING ACCORDING TO THE IOWA DEPARTMENT OF AGRICULTURE AND LAND STEWARDSHIP'S EMERALD ASH BORER (EAB) QUARANTINE ORDER. FOR MORE INFORMATION REFER TO [http://www.iowatreepests.com/eab\\_regulations.html](http://www.iowatreepests.com/eab_regulations.html).

09-27-94 271-9  
A SCRAPE SAMPLE WAS TAKEN FROM ONE AREA OF THIS BRIDGE TO GET AN INDICATION OF THE EXISTENCE OF THE LEVEL OF TOTAL CHROMIUM AND TOTAL LEAD. ANALYSIS OF TOTAL LEAD ON THIS SAMPLE WAS 10,200 PARTS PER MILLION (PPM). ANALYSIS OF TOTAL CHROMIUM ON THIS SAMPLE WAS 44,300 PPM. THESE ANALYSES SHOW THE EXISTENCE OF THESE TWO TOXIC CONSTITUENTS. LEVELS INDICATED BY THESE TESTS COULD CREATE CONDITIONS ABOVE REGULATORY LIMITS FOR HEALTH AND SAFETY REQUIREMENTS. NO OTHER CONSTITUENTS WERE ANALYZED. THE BIDDER SHOULD NOT RELY ON THE CONTRACTING AUTHORITY'S TESTING AND ANALYSIS FOR ANY PURPOSE OTHER THAN AS AN INDICATION OF THE EXISTENCE OF THESE TWO TOXIC CONSTITUENTS.

## PRECAST CONCRETE BOX OPTION

THE CULVERT CONTRACTOR MAY SUBSTITUTE PRECAST CONCRETE BOX SECTIONS AND PRECAST CONCRETE HEADWALLS IN PLACE OF THE CONCRETE CAST IN PLACE BARRELS AND HEADWALLS SHOWN ON THE PLANS.

IF A CONTRACTOR CHOOSES TO SUBSTITUTE PRECAST SECTIONS THE FOLLOWING SHALL APPLY:

- A. THE CONTRACTOR SHALL FURNISH AND INSTALL PRECAST CONCRETE BOX CULVERTS OF THE SIZE AND LENGTH AS SHOWN IN THE PLANS FOR CAST IN PLACE CONCRETE BOX CULVERTS IN ACCORDANCE WITH SECTION 2415 OF THE STANDARD SPECIFICATIONS.
- B. THE CONTRACTOR SHALL FURNISH AND INSTALL EYE BOLT TIES ON EACH SIDE OF EACH JOINT. EYE BOLT TIES SHALL BE INSTALLED WITH NUTS ON INSIDE OF BARREL. THE MAIN SECTION JOINTS WILL HAVE ONE TIE ON EACH SIDE OF THE BARREL EXCEPT THE LAST THREE. BARREL TO BARREL JOINTS AT EACH END SHALL HAVE TWO TIES PER SIDE WITH THE BOTTOM ROW OF TIES LOCATED 1'-8" ABOVE TOP OF BARREL FLOOR.
- C. THE CONTRACTOR SHALL FURNISH AND INSTALL AN APPROVED BITUMINOUS SEAL MATERIAL FOR EACH JOINT AS PER MATERIALS I.M. 491.09. MATERIAL SHALL BE INSTALLED IN ACCORDANCE WITH THE RECOMMENDATIONS OF THE MANUFACTURER AND SHALL EXTEND VERTICALLY 8 INCHES ABOVE THE BOTTOM FILLET.
- D. THE CONTRACTOR SHALL FURNISH AND INSTALL A 24" WIDE STRIP OF ENGINEERING FABRIC COMPLETELY AROUND THE TOP AND SIDES OF EACH JOINT WITH A MINIMUM OVERLAP OF 18 INCHES. THE FABRIC SHALL BE CENTERED WITH 1 FOOT ON EACH SIDE OF THE JOINT. THE FABRIC SHALL BE ATTACHED TO THE WALLS AND TOP OF EACH SECTION TO PREVENT THE FABRIC FROM SLIPPING OFF THE JOINT DURING BACKFILLING OPERATIONS. ATTACHMENT METHODS SHALL BE APPROVED BY THE ENGINEER. THE ENGINEERING FABRIC SHALL MEET THE MATERIAL REQUIREMENTS IN ACCORDANCE WITH ARTICLE 4198.01, B, 3, OF THE STANDARD SPECIFICATIONS.
- E. THE CONTRACTOR SHALL FURNISH AND INSTALL LIFTING HOLE PLUGS FOR EACH SECTION. LIFTING HOLES SHALL BE PLUGGED WITH A PRECAST CONCRETE PLUG, SEALED AND COVERED WITH MASTIC OR MORTAR.
- F. THE CURTAIN WALL SHALL EXTEND THE SAME DISTANCE BELOW THE CULVERT INVERT AS THE CURTAIN WALL FOR THE CAST IN PLACE BOX SHOWN ON THE PLANS.
- G. SHEET PILE SHALL BE DRIVEN BEHIND CURTAIN WALL TO DEPTH SHOWN IN DETAIL ON PLAN SHEET U1.
- H. GAP BETWEEN ADJACENT BARRELS SHALL BE A NOMINAL 12 INCHES. GAP SHALL BE CENTERED ON CENTERLINE OF CULVERT. REFER TO DETAIL ON PLAN SHEET U1.
- I. SUBBASE CONFIGURATION SHALL BE THE SAME AS THE DETAILS ON PLAN SHEET U1 FOR THE CAST IN PLACE BOX. NO ADJUSTMENTS TO PLAN QUANTITIES WILL BE MADE DUE TO WIDER FOUNDATION NECESSITATED BY PRECAST OPTION.
- J. A 4 FOOT WIDE STRIP OF ENGINEERING FABRIC SHALL BE PLACED ON TOP OF THE SPECIAL BACKFILL FOUNDATION MATERIAL. THE ENGINEERING FABRIC SHALL MEET THE MATERIAL REQUIREMENTS IN ACCORDANCE WITH ARTICLE 4198.01, B, 3, OF THE STANDARD SPECIFICATIONS. ENGINEERING FABRIC SHALL BE PLACED THE FULL LENGTH OF THE PRECAST CULVERT, INCLUDING END SECTIONS. THE ENGINEERING FABRIC SHALL BE CENTERED OVER THE CENTERLINE OF CULVERT BEFORE THE PRECAST CULVERTS ARE PLACED.
- K. A 4" DIAMETER SUBDRAIN SHALL TERMINATE AND BE CAPPED AT THE UPSTREAM END 12 INCHES SHORT OF THE END OF THE APRON OF THE END OF SECTION. THE SUBDRAIN SHALL OUTLET DOWNSTREAM AT THE END OF THE APRON OF THE END SECTION. THE SUBDRAIN SHALL BE SURROUNDED BY POROUS BACKFILL IN ACCORDANCE WITH SECTION 4131 OF THE STANDARD SPECIFICATIONS. NO COMPACTION OF THE POROUS BACKFILL IS REQUIRED.
- L. POROUS BACKFILL SHALL BE PLACED BETWEEN THE PRECAST BARREL WALLS UP TO 8 INCHES FROM THE TOP OF THE BARREL SLABS. POROUS BACKFILL SHALL ALSO BE PLACED BETWEEN THE END SECTIONS UP TO 8 INCHES FROM THE TOP OF THE WALLS AND 16 INCHES SHORT OF THE END OF THE APRON OF THE END SECTION. THE POROUS BACKFILL SHALL BE IN ACCORDANCE WITH SECTION 4131 OF THE STANDARD SPECIFICATIONS.
- M. A CONCRETE CAP SHALL BE PLACED ON TOP OF THE POROUS BACKFILL BETWEEN THE PRECAST CULVERTS FOR A DEPTH OF 8 INCHES FROM THE TOP OF THE BARREL SLABS, THE TOP OF THE END SECTION WALLS, AND TO A 16 INCH DEPTH AT THE ENDS OF THE APRON OF THE END SECTIONS. THE CONCRETE SHALL BE CLASS C CONCRETE IN ACCORDANCE WITH SECTION 2403 OF THE STANDARD SPECIFICATIONS.
- N. LENGTH OF TYPE 1 PARAPETS SHALL BE INCREASED SO THE ADJOINING ENDS WILL ABUT AGAINST EACH OTHER AT THE CENTERLINE OF CULVERT FOR SIDE-BY-SIDE PRECAST CULVERT STRUCTURES.
- O. LENGTH OF TYPE 3 LINTEL BEAMS AND PARAPETS SHALL BE INCREASED SO THE ADJOINING ENDS WILL ABUT AGAINST EACH OTHER AT THE CENTERLINE OF CULVERT FOR SIDE-BY-SIDE PRECAST CULVERT STRUCTURES.
- P. LENGTH OF CURTAIN WALLS SHALL BE SHORTENED SO THE ADJOINING ENDS WILL ABUT AGAINST EACH OTHER AT THE CENTERLINE OF CULVERT FOR SIDE-BY-SIDE PRECAST CULVERT STRUCTURES.
- Q. NO ADJUSTMENT WILL BE MADE TO PLAN QUANTITIES DUE TO CONSTRUCTION OF THE PRECAST ALTERNATE.

BEFORE BEGINNING CONSTRUCTION THE CONTRACTOR SHALL SUBMIT DETAILS OF THE PROPOSED PRECAST BOX SECTIONS AND HEADWALL TO THE CRAWFORD COUNTY ENGINEER FOR APPROVAL. THE DETAILS SHALL INCLUDE THE FOLLOWING:

1. A SITUATION PLAN DRAWING SHOWING THE BACK OF PARAPET DIMENSION FOR THE LINE OF THE CULVERT SECTIONS.
2. A DETAIL OF THE PRECAST CULVERT AND HEADWALL SECTIONS SHOWING A CROSS SECTION VIEW OF THE SECTION, STEEL LOCATIONS, DIMENSIONS, ETC.
3. A DETAIL OF THE INLET AND OUTLET HEADWALL SHOWING DIMENSIONS, SLOPES, AND PROPOSED CONNECTION OF 48 IN. DIA. SUBDRAIN.
4. A DETAIL OF THE PARAPET SHOWING A CROSS SECTION WITH DIMENSIONS AND A DETAIL OF HOW IT IS ATTACHED TO THE HEADWALL.
5. A DETAIL OF THE CURTAIN WALL SHOWING A CROSS SECTION WITH DIMENSIONS AND A DETAIL OF HOW IT IS ATTACHED TO THE HEADWALL.

THE ABOVE DETAILS SHALL BE CERTIFIED BY AN ENGINEER LICENSED IN THE STATE OF IOWA. THE CONTRACTOR SHALL ALLOW SEVEN DAYS FOR THE COUNTY ENGINEER'S REVIEW. FOR CONSTRUCTION OF THE PRECAST ALTERNATE THE CONTRACTOR WILL BE PAID THE PRICES BID FOR THE PLAN QUANTITIES OF "STRUCTURAL CONCRETE (R.C.B. CULVERT)" AND "REINFORCING STEEL".

POLLUTION PREVENTION PLAN

110-12A  
10-18-18

This project is regulated by the requirements of the Iowa Department of Natural Resources (DNR) National Pollutant Discharge Elimination System (NPDES) General Permit No. 2 OR an Iowa Department of Natural Resources (DNR) National Pollutant Discharge Elimination System (NPDES) individual storm water permit. The Contractor shall carry out the terms and conditions of this permit and the Pollution Prevention Plan (PPP).

This Base PPP includes information on Roles and Responsibilities, Project Site Description, Controls, Maintenance Procedures, Inspection Requirements, Non-Storm Water Controls, Potential Sources of Off Right-of-Way Pollution, and Definitions. This plan references other documents rather than repeating the information contained in the documents. A copy of this Base Pollution Prevention Plan, amended as needed per plan revisions or by contract modification, will be readily available for review.

All contractors shall conduct their operations in a manner that controls pollutants, minimizes erosion, and prevents sediments from entering waters of the state and leaving the highway right-of-way. The prime contractor shall be responsible for compliance and implementation of the PPP for their entire contract. This responsibility shall be further shared with subcontractors whose work is a source of potential pollution as defined in this PPP.

I. ROLES AND RESPONSIBILITIES

A. Designer:

1. Prepares Base PPP included in the project plan.
2. Prepares Notice of Intent (NOI) submitted to Iowa DNR.
3. Signature authority on the Base PPP and NOI.

B. Contractor/Subcontractor:

1. Affected contractors/subcontractors are co-permittees with the contracting authority and will sign a certification statement adhering to the requirements of the NPDES permit and this PPP plan. Affected contractors/subcontractors are anyone responsible for sediment or erosion controls or involved in land disturbing activities. All co-permittees are legally required under the Clean Water Act and the Iowa Administrative Code to ensure compliance with the terms and conditions of this PPP.
2. Submit an Erosion Control Implementation Plan (ECIP) according to Specifications Section 2602 and any additional plan notes.
3. Install and maintain appropriate controls.
4. Supervise and implement good housekeeping practices.
5. Conduct joint required inspections of the site with inspection staff.
6. Comply with training and certification requirements of Specifications Section 2602.
7. Signature authority on Co-Permittee Certification Statements and storm water inspection reports.

C. RCE/Inspector:

1. Update PPP whenever there is a change in design, construction, operation or maintenance, which has a significant effect on the discharge of pollutants from the project.
2. Maintain an up-to-date record that identifies contractors and subcontractors as co-permittees.
3. Make these plans available to the DNR upon their request.
4. Conduct joint required inspections of the site with the contractor/subcontractor.
5. Complete an inspection report after each inspection.
6. Signature authority on storm water inspection reports and Notice of Discontinuation (NOD).

II. PROJECT SITE DESCRIPTION

- A. This Pollution Prevention Plan (PPP) is for the construction of a Crawford County Twin RCB Culvert on county road 0 Avenue over Willow Creek.
- B. This PPP covers approximately 3.2 acres with an estimated 1.5 acres being disturbed. The portion of the PPP covered by this contract has 1.5 acres disturbed.
- C. The PPP is located in an area of one soil association (Monona-Ide-Napier). The estimated weighted average runoff coefficient number for this PPP after completion will be 0.23.
- D. Storm Water Site Map - Multiple sources of information comprise the base storm water site map including:
  1. Drainage patterns - Plan and Profile sheets and Situation plans.
  2. Proposed Slopes - Cross Sections.
  3. Areas of Soil Disturbance - construction limits shown on Plan and Profile sheets.
  4. Location of Structural Controls - Tabulations on C sheets.
  5. Locations of Non-structural Controls - Tabulations on C sheets.
  6. Locations of Stabilization Practices - generally within construction limits shown on Plan and Profile sheets.
  7. Surface Waters (including wetlands) - Project Location Map and Plan and Profile sheets.
  8. Locations where storm water is discharged - Plan and Profile sheets.
- E. The base site map is amended by contract modifications and progress payments (fieldbook entries) of completed erosion control work. Also, due to project phasing, erosion and sediment controls shown on project plans may not be installed until needed, based on site conditions. For example, silt fence ditch checks will typically not be installed until the ditch has been installed. Installed locations may also be modified from tabulation locations by field staff. Installed locations will be documented by fieldbook entries.
- F. Runoff from this work will flow into Willow Creek.

III. CONTROLS

- A. The contractor's ECIP specified in Article 2602.03 for accomplishment of storm water controls should clearly describe the intended sequence of major activities and for each activity define the control measure and the timing during the construction process that the measure will be implemented.
- B. Preserve vegetation in areas not needed for construction.
- C. Sections 2601 and 2602 of the Standard Specifications define requirements to implement erosion and sediment control measures. Actual quantities used and installed locations may vary from the Base PPP and amendment of the plan will be documented via fieldbook entries or by contract modification. Additional erosion and sediment control items may be required as determined by the inspector and/or contractor during storm water monitoring inspections. If the work involved is not applicable to any contract items, the work will be paid for according to Article 1109.03 paragraph B.

1. EROSION AND SEDIMENT CONTROLS

a. Stabilization Practices

- 1) Site plans will ensure that existing vegetation or natural buffers are preserved where attainable and disturbed portions of the site will be stabilized.
- 2) Stabilization practices shall be initiated as soon as practicable in portions of the site where construction activities have temporarily or permanently ceased.
- 3) Temporary stabilizing seeding shall be completed as the disturbed areas are constructed. If construction activity is not planned to occur in a disturbed area for at least 21 days, the area shall be stabilized by temporary seeding or mulching within 14 days.
- 4) Permanent and Temporary Stabilization practices to be used for this project are located in the Estimated Project Quantities (100-0A, 100-1A, or 100-1C) and Estimate Reference Information (100-4A) located on the C sheets of the plan. Typical drawings detailing construction of the practices to be used on this project are referenced in the Standard Road Plans Tabulation.
- 5) Preservation of existing vegetation within right-of-way or easements will act as vegetative buffer strips.
- 6) Preservation of topsoil: Bid items to be used for this project are located in the Estimated Project Quantities (100-0A, 100-1A, or 100-1C) and Estimate Reference Information (100-4A) located on the C sheets of the plan. Additional information may be found in Tabulations in the C or T sheets of the plans or is referenced in Standard Specifications Section 2105.

b. Structural Practices

- 1) Structural practices will be implemented to divert flows from exposed soils and detain or otherwise limit runoff and the discharge of pollutants from exposed areas of the site. Additionally, structural practices may include: silt basins that provide 3600 cubic feet of storage per acre drained or equivalent sediment controls, outlet structures that withdraw water from surface when discharging basins, and controls to direct storm water to vegetated areas.

POLLUTION PREVENTION PLAN

110-12A  
10-18-18

2) Structural practices to be used for this project are located in the Estimated Project Quantities (100-0A, 100-1A, or 100-1C) and Estimate Reference Information (100-4A) located on the C sheets of the plan, as well as all other item specific Tabulations. Typical drawings detailing construction of the devices to be used on this project can be found on the B sheets of the plans or are referenced in the Standard Road Plans Tabulation.

c. Storm Water Management

- 1) Measures shall be installed during the construction process to control pollutants in storm water discharges that will occur after construction operations have been completed. This may include velocity dissipation devices at discharge locations and along length of outfall channel as necessary to provide a non-erosion velocity flow from structure to water course. If included with this project, these items are located in the Estimated Project Quantities (100-0A, 100-1A, or 100-1C) and Estimate Reference Information (100-4A) located on the C sheets of the plan, as well as all other item specific Tabulations. Typical drawings detailing construction of the practices to be used on this project are referenced in the Standard Road Plans Tabulation. The installation of these devices may be subject to Section 404 of the Clean Water Act.

2. OTHER CONTROLS

- a. Contractor disposal of unused construction materials and construction material wastes shall comply with applicable state and local waste disposal, sanitary sewer, or septic system regulations. In the event of a conflict with other governmental laws, rules and regulations, the more restrictive laws, rules or regulations shall apply.
  - 1) Vehicle Entrances and Exits - Construct and maintain entrances and exits to prevent tracking of sediments onto roadways.
  - 2) Material Delivery, Storage and Use - Implement practices to prevent discharge of construction materials during delivery, storage, and use.
  - 3) Stockpile Management - Install controls to reduce or eliminate pollution of storm water from stockpiles of soil and paving.
  - 4) Waste Disposal - Do not discharge any materials, including building materials, into waters of the state, except as authorized by a Section 404 permit.
  - 5) Spill Prevention and Control - Implement procedures to contain and clean-up spills and prevent material discharges to the storm drain system and waters of the state.
  - 6) Concrete Residuals and Washout Wastes - Designate temporary concrete washout facilities for rinsing out concrete trucks. Provide directions to truck drivers where designated washout facilities are located. Designated washout areas should be located at least 50 feet away from storm drains, streams or other water bodies. Care should be taken to ensure these facilities do not overflow during storm events.
  - 7) Concrete Grooving/Grinding Slurry - Do not discharge slurry to a waterbody or storm drain. Slurry may be applied on foreslopes or removed from the project.
  - 8) Vehicle and Equipment Storage and Maintenance Areas - Perform on site fueling and maintenance in accordance with all environment laws such as proper storage of onsite fuels and proper disposal of used engine oil or other fluids on site. Employ washing practices that prevent contamination of surfaces and ground water from wash water.
  - 9) Litter Management - Ensure employees properly dispose of litter.
  - 10) Dewatering - Properly treat water to remove suspended sediment before it re-enters a waterbody or discharges off-site. Measures are also to be taken to prevent scour erosion at dewatering discharge point.

3. APPROVED STATE OR LOCAL PLANS

During the course of this construction, it is possible that situations will arise where unknown materials will be encountered. When such situations are encountered, they will be handled according to all federal, state, and local regulations in effect at the time.

IV. MAINTENANCE PROCEDURES

The contractor is required to maintain all temporary erosion and sediment control measures in proper working order, including cleaning, repairing, or replacing them throughout the contract period. This shall begin when the features have lost 50% of their capacity.

V. INSPECTION REQUIREMENTS

- A. Inspections shall be made jointly by the contractor and the contracting authority at least once every seven calendar days. Storm water monitoring inspections will include:
  1. Date of the inspection.
  2. Summary of the scope of the inspection.
  3. Name and qualifications of the personnel making the inspection.
  5. Review erosion and sediment control measures within disturbed areas for the effectiveness in preventing impacts to receiving waters.
  6. Major observations related to the implementation of the PPP.
  7. Identify corrective actions required to maintain or modify erosion and sediment control measures.
- B. Include storm water monitoring inspection reports in the Amended PPP. Incorporate any additional erosion and sediment control measures determined as a result of the inspection. Immediately begin corrective actions on all deficiencies found within 3 calendar days of the inspection.

VI. NON-STORM WATER DISCHARGES

This includes subsurface drains (i.e. longitudinal and standard subdrains) and slope drains. The velocity of the discharge from these features may be controlled by the use of patio blocks, Class A stone, erosion stone or other appropriate materials. This also includes uncontaminated groundwater from dewatering operations, which will be controlled as discussed in Section III of the PPP.

VII. POTENTIAL SOURCES OF OFF RIGHT-OF-WAY (ROW) POLLUTION

Silt, sediment, and other forms of pollution may be transported onto highway right-of-way (ROW) as a result of a storm event. Potential sources of pollution located outside highway ROW are beyond the control of this PPP. Pollution within highway ROW will be conveyed and controlled per this PPP.

VIII. DEFINITIONS

- A. Base PPP - Initial Pollution Prevention Plan.
- B. Amended PPP - May include Plan Revisions or Contract Modifications for new items, storm water monitoring inspection reports, and fieldbook entries made by the inspector.
- C. IDR - Inspector's Daily Report - this contains the inspector's daily diary and bid item postings.
- D. Controls - Methods, practices, or measures to minimize or prevent erosion, control sedimentation, control storm water, or minimize contaminants from other types of waste or materials. Also called Best Management Practices (BMPs).
- E. Signature Authority - Representative from Designer, Contractor/Subcontractor, or RCE/Inspector authorized to sign various storm water documents.

CERTIFICATION STATEMENT

I certify under penalty of law that this document and all attachments were prepared under my direction or supervision in accordance with a system designed to assure that qualified personnel properly gathered and evaluated the information submitted. Based on my inquiry of the person or persons who manage the system, or those persons directly responsible for gathering the information, the information submitted is, to the best of my knowledge and belief, true, accurate, and complete. I am aware that there are significant penalties for submitting false information, including the possibility of fine and imprisonment for knowing violations.

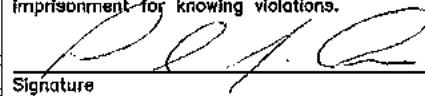
  
Signature

Paul J. Assmann  
Printed or Typed Name

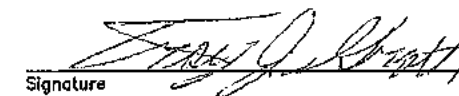
  
Signature

TROY J. GROTH  
Printed or Typed Name

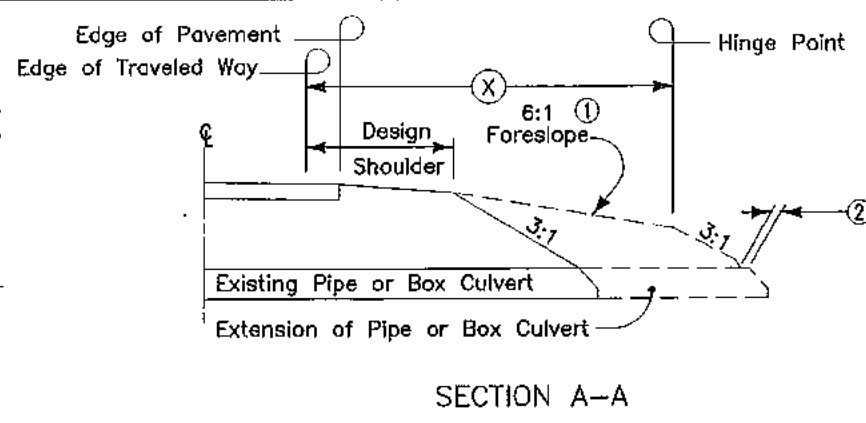
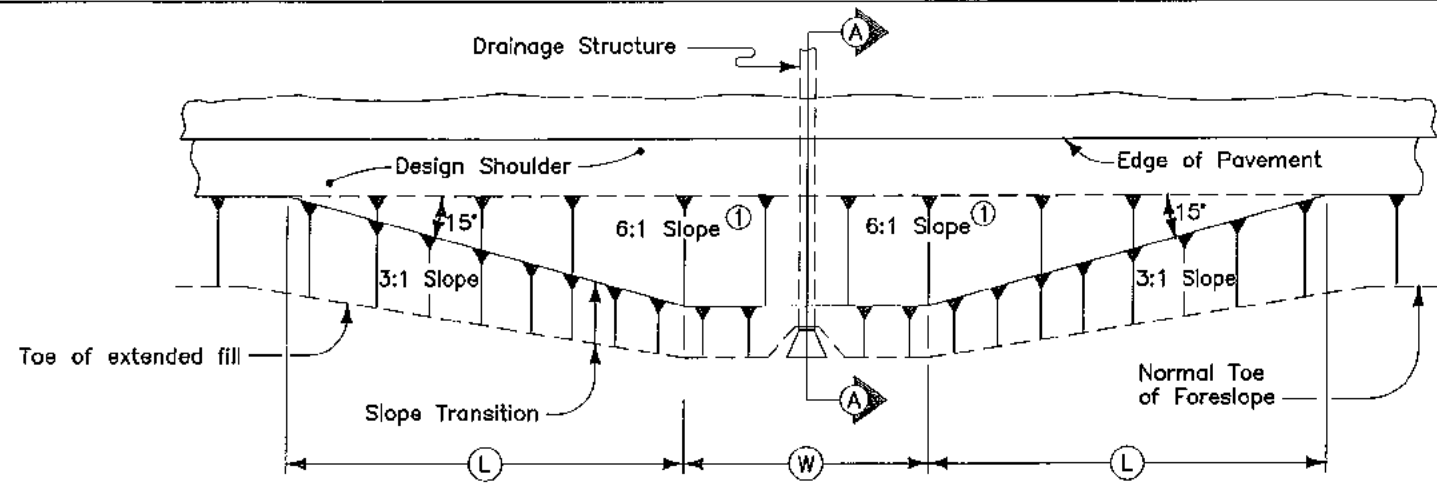

Notes:  
 At locations where an extended or newly constructed drainage structure extends beyond the normal foreslope cover, the foreslope shall be flattened as indicated so as to cover the structure. Minimum earth cover is 6".

① 6:1 Maximum - Slope may be flatter.  
 ② 6" Minimum for pipe installations or to top of headwall on R.C.B.  
 (W) = Pipe or R.C.B. width plus 20 feet each side.  
 (X) = Clear Zone.

STRUCTURE LOCATION		(W)	(L)	(X)
STATION	SIDE	FEET	FEET	FEET
20+30	L & R	78.4	11.2	6

DETAILS OF  
BARNROOF FORESLOPE  
AT DRAINAGE STRUCTURE

TABULATION OF EARTHWORK QUANTITIES

STA.	CUT	ADD. CUT	FILL +35%	ADD. FILL	TOTAL CUT	TOTAL FILL+35%	BALANCE
17+00							
18+00	79.1		68.3		79.1	68.3	
19+00	298.5		202.3		298.5	202.3	
19+66.48	309.0		262.3		309.0	262.3	
20+00	124.8		725.8	150	124.8	874.8	
20+52.52	249.7		1206.0	34.1	249.7	1240.1	
21+00	208.3		234.3		208.3	234.3	
22+00	163.3		142.5	190	163.3	331.5	
24+00	145.9		85.0		145.9	85.0	
TOTAL					1578.7	3298.5	

PLACEMENT OF QUANTITIES  
TWIN 12'x12'x54' RCB CULVERT

LOCATION	CONCRETE C.Y.				STEEL LBS.
	SLAB	FLOOR	WALLS	TOTAL	
INLET HEADWALL, 45' SKEW	4.0	92.0	42.1	138.1	15584
INLET BARREL SECTION, 17'-0	15.3	16.3	21.9	53.5	9448
BARREL SECTION, 20'-0	18.0	19.1	25.8	63.0	11115
OUTLET BARREL SECTION, 17'-0	15.3	16.3	21.9	53.5	9448
OUTLET HEADWALL, 45' SKEW	4.0	92.0	42.1	138.1	15584
5r1 DOWEL BARS (2 SETS REQ'D @ 80 LBS.)					160
TOTAL	56.6	235.7	153.8	446.2	61339

NOTE: FOR GENERAL INFORMATION, NOTES, SPECIFICATIONS & DESIGN STRESSES REFER TO IOWA D.O.T. HIGHWAY DIVISION STANDARD TWRCB-G1-12.  
 FOR DETAILS AND NOTES NOT SHOWN REFER TO STANDARD BRIDGE PLANS LISTED ON PLAN SHEET C1.

TABULATION OF SILT FENCES  
Refer to EC-201

Location			Length LF	Remarks
Begin Station	End Station	Side		
20+00	24+00	L	466.0	
SUBTOTAL			466.0	
+25% FOR REPLACEMENTS			116.5	
TOTAL			582.5	

TABULATION OF SILT FENCES FOR DITCH CHECKS  
Refer to EC-201

Type	Location Station	Side	Length LF	Remarks
1	17+50	R	20	
1	18+00	L	20	
1	19+50	R	20	
1	20+00	L	20	
TOTAL			80	TABULATED QUANTITY
TOTAL +50%			120	BID QUANTITY

CLEARING AND GRUBBING

Location Station to Station or Milepost to Milepost or Description	Direction of Travel	Work and Material Type	Trees, Stumps, and Logs and Down Timber Material Diameters							All other Materials		Remarks
			3"-6"	>6"-9"	>9"-12"	>12"-15"	>15"-18"	>18"-24"	>24"-30"	Length	Width	
										FT	FT	
19+00 - 20+50	EAST	CLEARING AND GRUBBING			1			2	3			

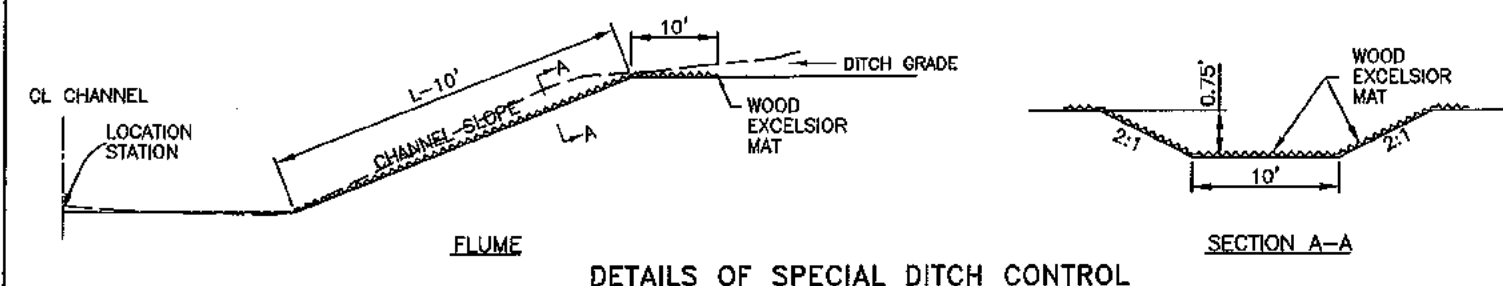

DETAILS OF SPECIAL DITCH CONTROL

ROLLED EROSION CONTROL  
Refer to EC-101, EC-103 and EC-104

Location				(L)	(W)	Turf Reinforcement Mat (TRM) (EC-104)				Slope Protection (EC-103)	Special Ditch Control (EC-101)	Remarks
Road Identification	Begin Station	End Station	Side			Type 1	Type 2	Type 3	Type 4			
				FT	FT	Squares	Squares	Squares	Squares	Squares	Squares	
O AVENUE	119+60		RT.	112	16						17.9	SEE DETAILS THIS SHEET
TOTAL											17.9	

SAFETY CLOSURES  
Refer to Section 2518 of the Standard Specifications

STATION	CLOSURE TYPE		REMARKS
	Road Qty.	Hazard Qty.	
16+50	-	1	WEST END
24+50	-	1	EAST END
TOTAL		2	

PARCEL NUMBER	PROPERTY OWNER
1	ERVIN P. KUHLMANN
2	RAYMOND H. & SHARON K. GOSCH

WILLOW TWP.  
T-83N R-41W

BENCH MARKS	ELEVATION
BM#1 STA. 18+49, 32' RT. RR SPIKE IN PP	1322.07
BM#2 STA. 22+18, 32' RT. RR SPIKE IN PP	1327.09

SW COR.  
9-83-41  
FD. ORANGE  
CAP #14709

15+00

25+00

O AVE

EXIST. R-O-W

SECTION LINE &  
SURVEY BASELINE

PROP. R-O-W

EXIST. R-O-W

POT STA. 17+00  
BEGIN PROJECT

PROP. R-O-W

PROP. R-O-W

POT STA. 24+00  
END PROJECT

EXIST. R-O-W

S1/4 COR.  
9-83-41  
FD. ORANGE  
CAP #14709

② SE1/4 SW1/4  
9-83-41

① NE1/4 NW1/4  
16-83-41

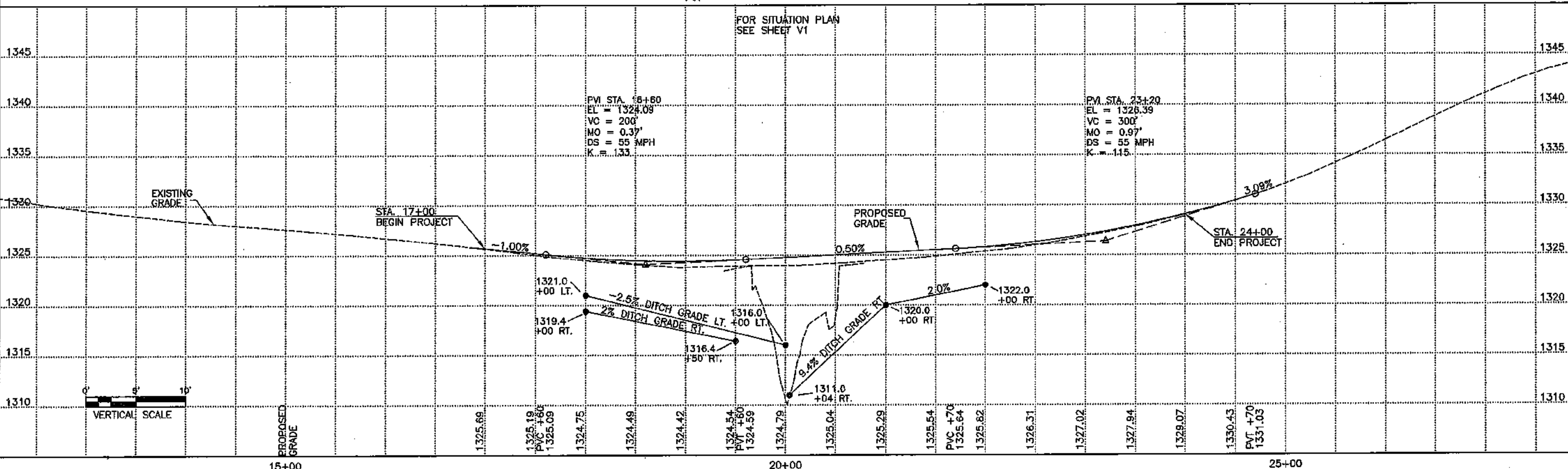
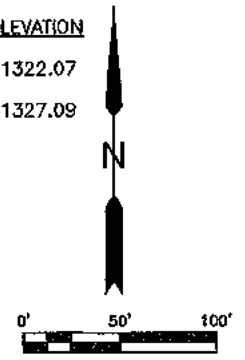

GENERAL INFORMATION  
THIS SURVEY IS IN ENGLISH UNITS.

BENCH MARKS	ELEVATION
BM#1 STA. 18+49.32' RT. RR SPIKE IN PP	1322.07
BM#2 STA. 22+18.32' RT. RR SPIKE IN PP	1327.09



UNLESS NOTED:  
ALL TIES ARE "X" NAILS

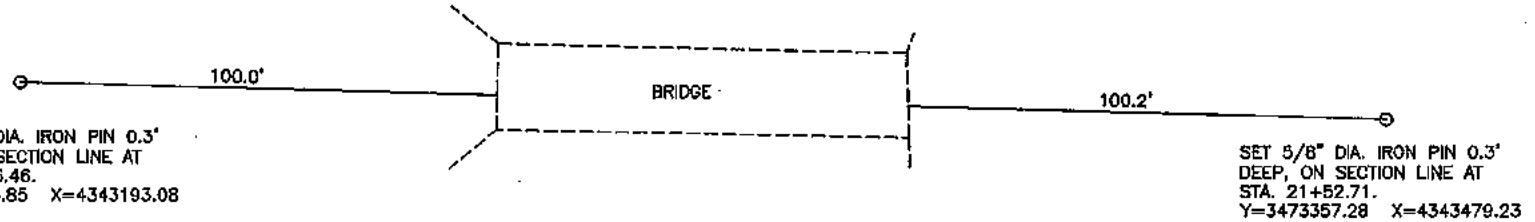
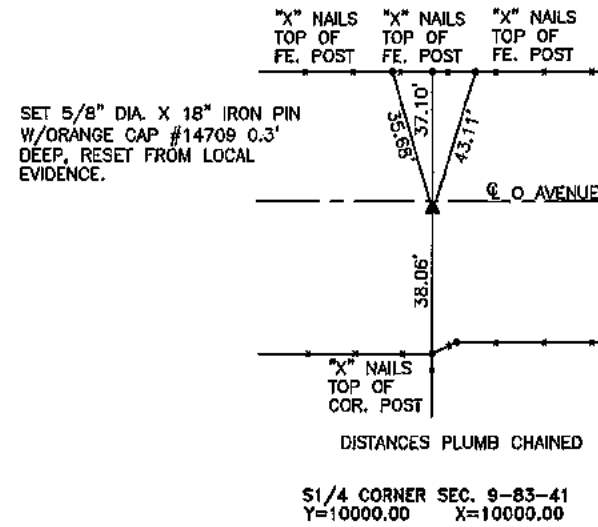
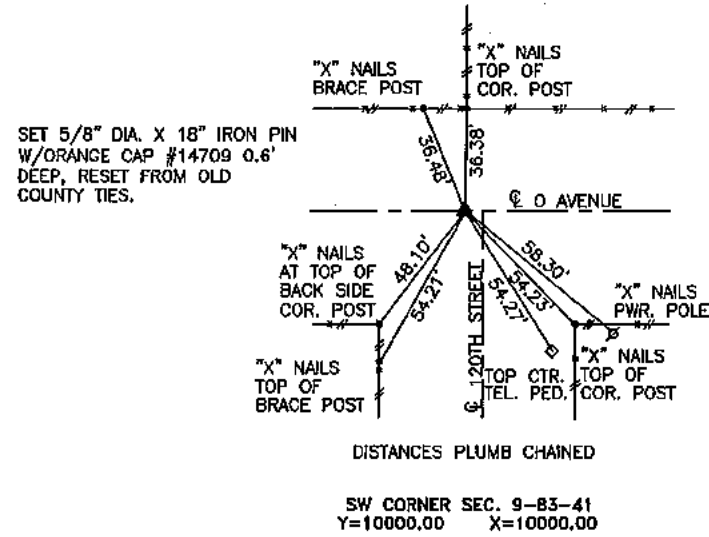

ALIGNMENT COORDINATES

101-16  
10-20-09

Name	Location	Point on Tangent		Begin Spiral		Begin Curve		Simple Curve PI or Master PI of SCS		End Curve		End Spiral	
		Station	Coordinates		Station	Coordinates		Station	Coordinates		Station	Coordinates	
			Y (Northing)	X (Easting)		Y (Northing)	X (Easting)		Y (Northing)	X (Easting)		Y (Northing)	X (Easting)
O AVE.		17+00.00	3473369.2985	4343026.6788									
O AVE.		24+00.00	3473350.7070	4343726.4319									

DETAILS OF REFERENCE INFORMATION

All References Plumb Distances  
(unless otherwise noted)



**LOG OF EXPLORATORY BORING** Sheet 1 of 1

Job Number: 64803S      Boring No.: B-1  
 Project: 0 Avenue Bridge Replacement      Boring Location: Crawford County, IA  
 Date Started: 7/19/16      Drill Type: Hollow Stem  
 Date Completed: 7/19/16      Ground Elev.: 1323.7

Depth in Feet	Graphic Log	Sample Type	USCS	Blow Counts SPT (N) Blows/Foot	Moisture Content, %	Dry Density (pcf)	% Saturation	Hard Penetrometer (HSF)	Unconfined Comp. Strength (TSF)	Liquid Limit %	Plastic Limit %	Plasticity Index %	Cone Penetrometer (Blows per 1-3/4")
0-12	12-Inch Gravel Layer												
12-17	FILL, Lean Clay, Dark Gray Brown, Moist to Very Moist, Oxidized												
17-20	LEAN CLAY, Dark Gray Brown, Very Moist to Wet, Medium, Alluvium												
20-25	SILT, Light Gray, Wet, Very Soft, Alluvium												
25-30	LEAN CLAY, Olive Gray, Wet, Medium, Alluvium												
30-35	SILT, Olive Gray, Wet, Medium, Alluvium												
35-40	LEAN CLAY, Dark Gray, Wet, Medium, Alluvium												
40-45	POORLY GRADED SAND, Gray Brown, Wet, Medium Dense, Medium Grained, Alluvium												
45	END OF BORING AT 45 FEET FREE WATER WAS ENCOUNTERED AT 17 FEET AT TIME OF DRILLING												

**LOG OF EXPLORATORY BORING** Sheet 1 of 1

Job Number: 64803S      Boring No.: B-2  
 Project: 0 Avenue Bridge Replacement      Boring Location: Crawford County, IA  
 Date Started: 7/19/16      Drill Type: Hollow Stem  
 Date Completed: 7/19/16      Ground Elev.: 1324.1

Depth in Feet	Graphic Log	Sample Type	USCS	Blow Counts SPT (N) Blows/Foot	Moisture Content, %	Dry Density (pcf)	% Saturation	Hard Penetrometer (HSF)	Unconfined Comp. Strength (TSF)	Liquid Limit %	Plastic Limit %	Plasticity Index %	Cone Penetrometer (Blows per 1-3/4")
0-12	12-Inch Gravel Layer												
12-17	FILL, Lean Clay, Dark Gray Brown and Medium Brown, Moist to Very Moist												
17-20	LEAN CLAY, Dark Brown, Very Moist to Wet, Very Soft to Medium, Alluvium												
20-25	(Dark Gray Brown)												
25-30	(Dark Gray)												
30-35	(Light Gray)												
35-40	SILT, Olive Gray and Medium Brown, Wet, Medium, Alluvium												
40-45	POORLY GRADED SAND WITH GRAVEL, Gray Brown, Wet, Loose to Medium Dense, Coarse Grained, Alluvium												
45	END OF BORING AT 45 FEET FREE WATER WAS ENCOUNTERED AT 17.5 FEET AT TIME OF DRILLING												

GEOTECHNICAL INFORMATION PROVIDED HERewith IS THE SOLE RESPONSIBILITY OF CERTIFIED TESTING SERVICES, INC., WHOSE GEOTECHNICAL REPORT DATED JULY 21, 2016, COMPLETE WITH THE LICENSED ENGINEER'S SEAL AND CERTIFICATION, IS AVAILABLE FOR VIEWING.

**SOUNDING DATA**

NOTE: THESE SOUNDINGS WERE MADE FOR DESIGN PURPOSES AND ARE NOT GUARANTEED FOR CONSTRUCTION.

SOUNDINGS WERE TAKEN ON JULY 19, 2016.

SEE SHEET V1 FOR BORING LOCATIONS.



I HEREBY CERTIFY THAT THIS ENGINEERING DOCUMENT WAS PREPARED BY ME OR UNDER MY DIRECT PERSONAL SUPERVISION AND THAT I AM A DULY LICENSED PROFESSIONAL ENGINEER UNDER THE LAWS OF THE STATE OF IOWA.

*James A. Bertsch* 9-21-2016  
 JAMES A. BERTSCH, P.E. #12121      DATE

MY LICENSE RENEWAL DATE IS DECEMBER 31, 2016.

PAGES OR SHEETS COVERED BY THIS SEAL:  
 01

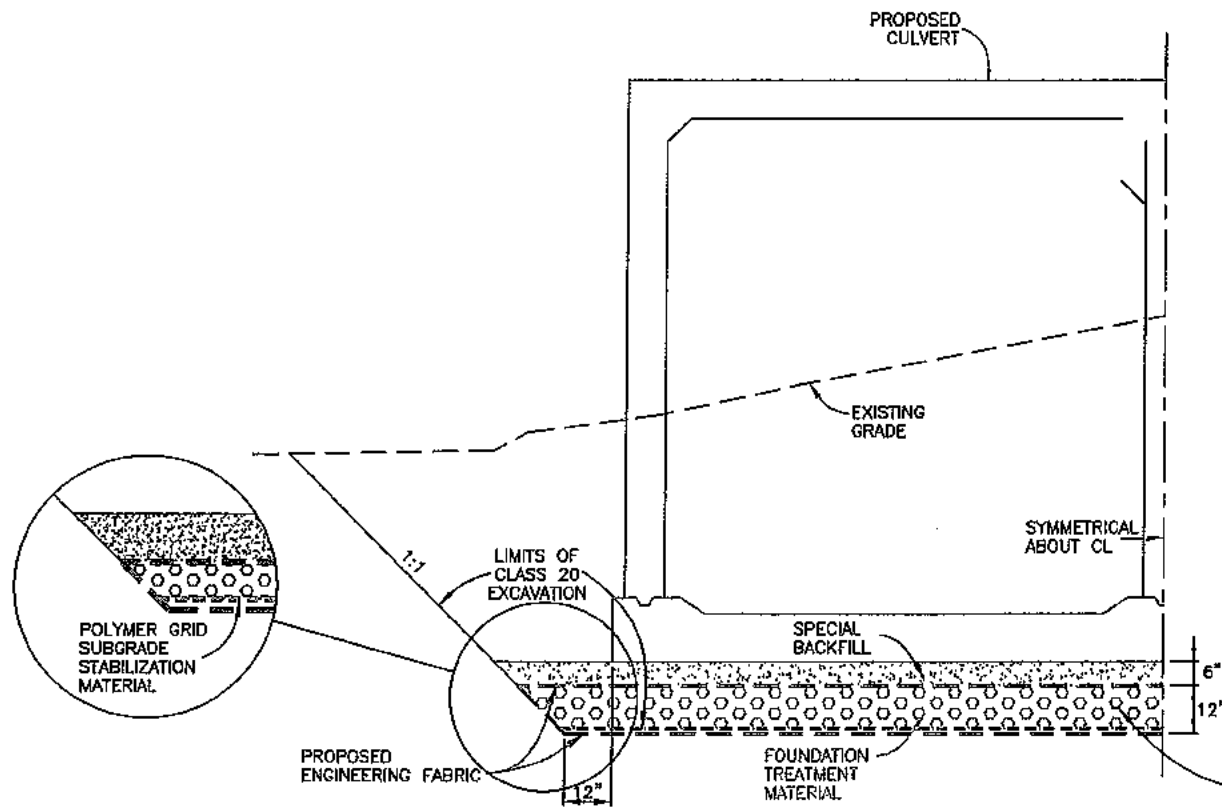

**CLASS 20 EXCAVATION & FOUNDATION TYPICAL SECTION**  
NOT TO SCALE

MINIMUM DEPTH OF FOUNDATION TREATMENT MATERIAL SHALL BE 12 INCHES. ACTUAL DEPTH REQUIRED WILL BE DETERMINED BY THE ENGINEER IN THE FIELD.

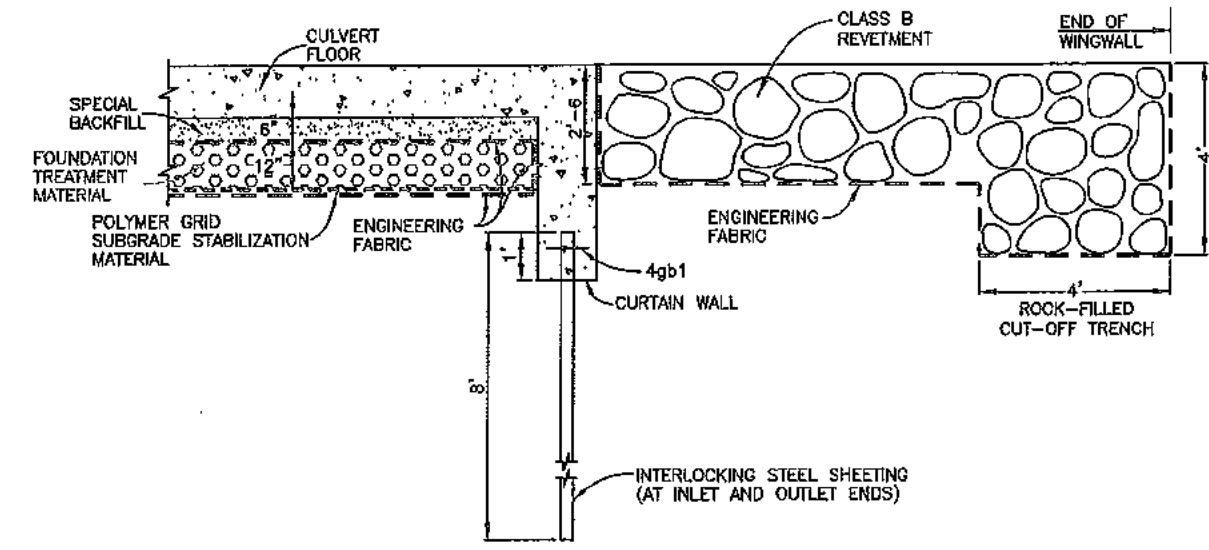

**SECTION AT HEADWALL CURTAIN WALL**  
NOT TO SCALE

NOTE:  
A HOLE LOCATED 3 INCHES DOWN FROM THE TOP AND ON THE VERTICAL CENTERLINE OF THE STEEL SHEETING IS TO BE PUNCHED OR FIELD CUT IN EACH PIECE OF SHEETING AND IS TO BE LARGE ENOUGH TO ACCOMMODATE A 4gb1 BAR. LENGTH OF 4gb1 BARS SHALL BE 11 INCHES. THIS WORK TO BE INCLUDED IN AND CONSIDERED INCIDENTAL TO THE PRICE BID FOR PILES, STEEL SHEET.

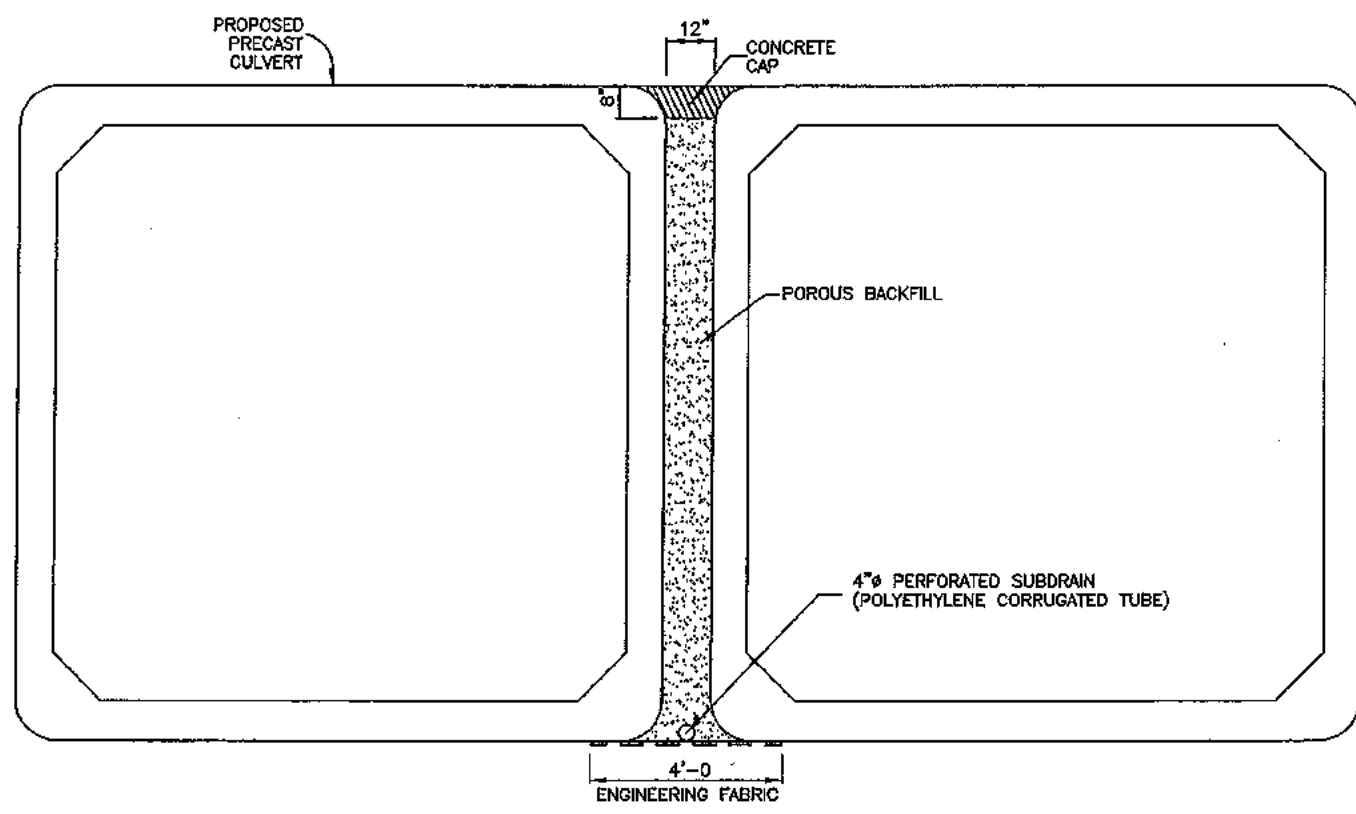

**PRECAST CULVERT DETAIL**  
NOT TO SCALE

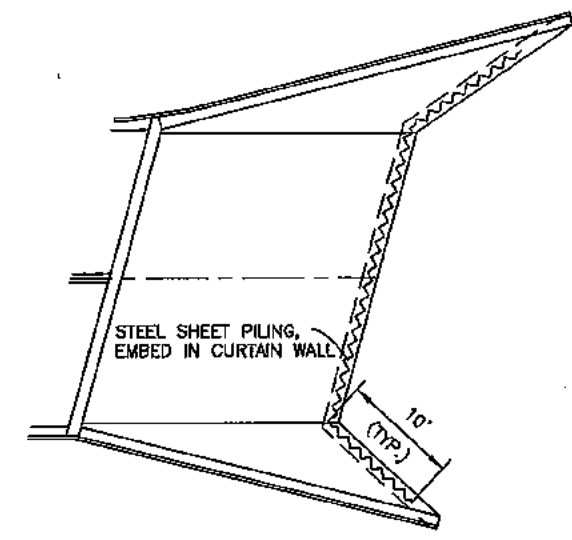

**STEEL SHEET PILE AT CURTAIN WALL**  
NOT TO SCALE

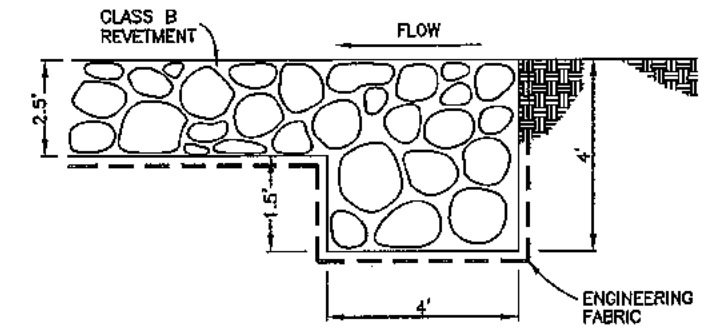

**TYPICAL UPSTREAM**

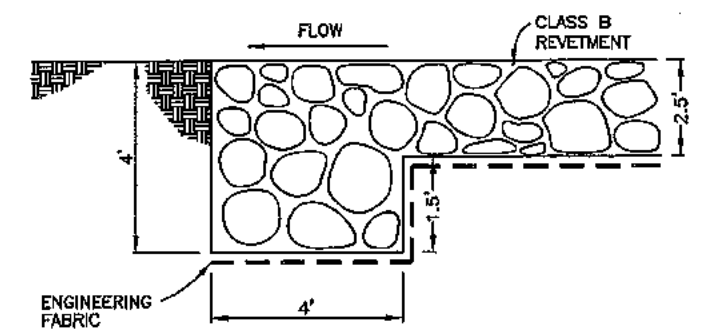

**TYPICAL DOWNSTREAM**

**ROCK-FILLED CUTOFF TRENCH DETAILS**  
NOT TO SCALE

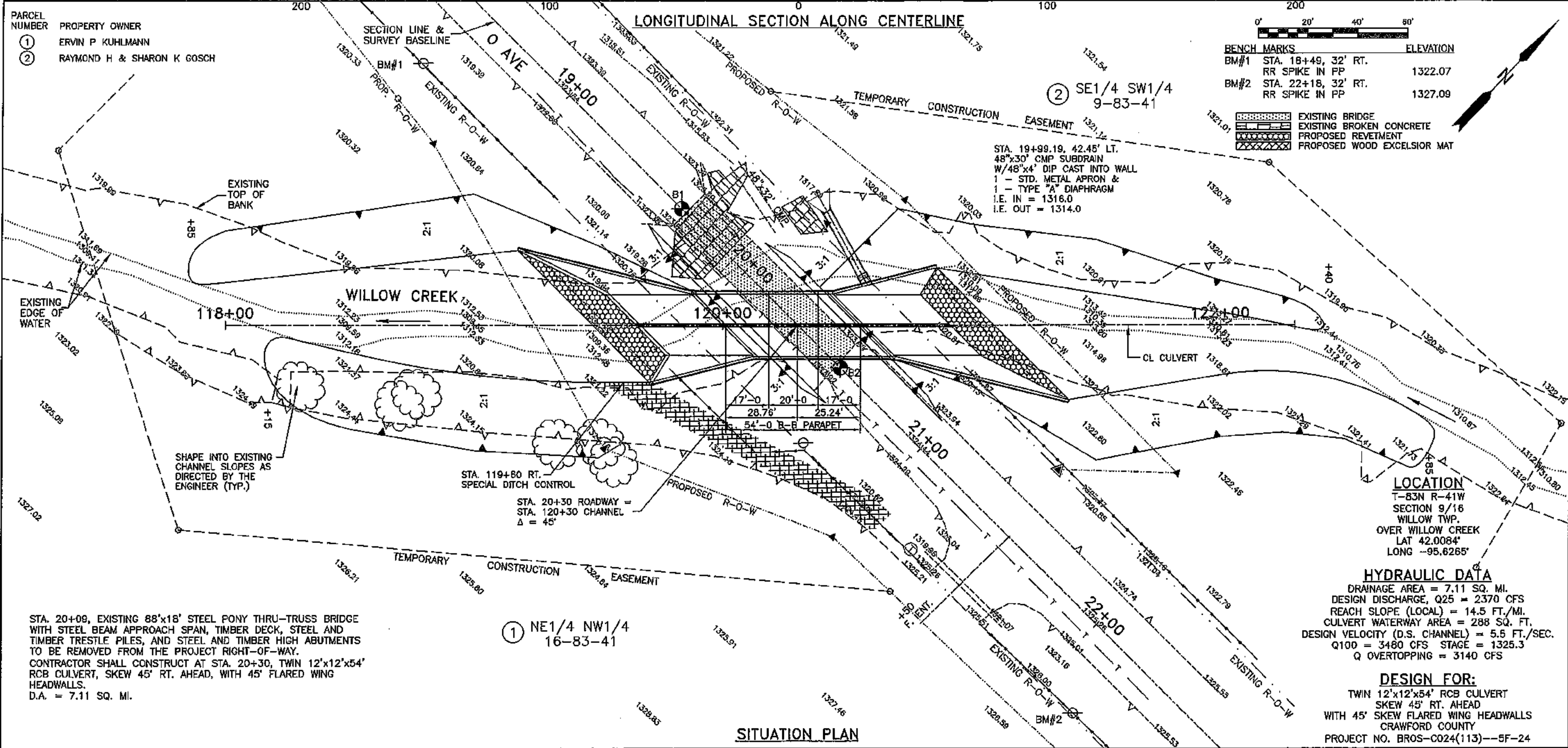
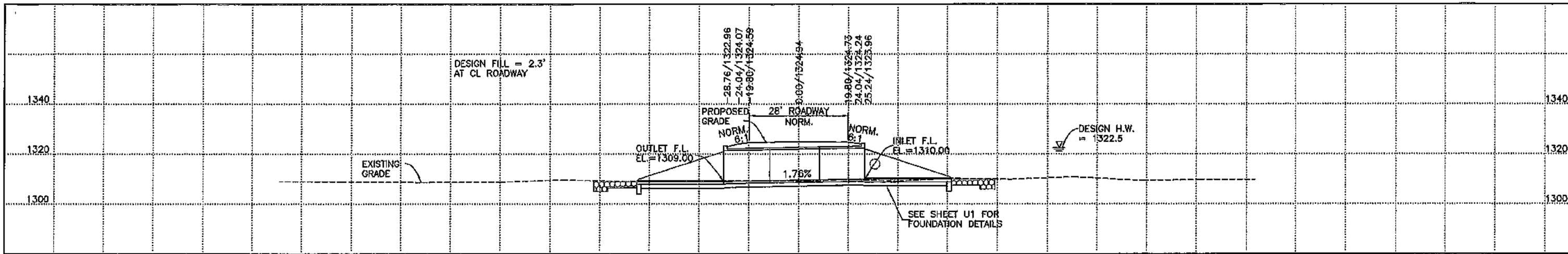

PARCEL NUMBER PROPERTY OWNER

① ERVIN P. KUHLMANN

② RAYMOND H & SHARON K GOSCH

BENCH MARKS ELEVATION

BM#1 STA. 18+49, 32' RT. RR SPIKE IN PP 1322.07

BM#2 STA. 22+18, 32' RT. RR SPIKE IN PP 1327.09

EXISTING BRIDGE

EXISTING BROKEN CONCRETE

PROPOSED REVETMENT

PROPOSED WOOD EXCELSIOR MAT

STA. 19+99.19, 42.45' LT.  
 48"x30" CMP SUBDRAIN  
 W/48"x4" DIP CAST INTO WALL  
 1 - STD. METAL APRON &  
 1 - TYPE "A" DIAPHRAGM  
 I.E. IN = 1316.0  
 I.E. OUT = 1314.0

LOCATION  
 T-83N R-41W  
 SECTION 9/16  
 WILLOW TWP.  
 OVER WILLOW CREEK  
 LAT 42.0084°  
 LONG -95.6265°

HYDRAULIC DATA  
 DRAINAGE AREA = 7.11 SQ. MI.  
 DESIGN DISCHARGE, Q25 = 2370 CFS  
 REACH SLOPE (LOCAL) = 14.5 FT./MI.  
 CULVERT WATERWAY AREA = 288 SQ. FT.  
 DESIGN VELOCITY (D.S. CHANNEL) = 5.6 FT./SEC.  
 Q100 = 3480 CFS STAGE = 1325.3  
 Q OVERTOPPING = 3140 CFS

DESIGN FOR:  
 TWIN 12'x12'x54' RCB CULVERT  
 SKEW 45° RT. AHEAD  
 WITH 45° SKEW FLARED WING HEADWALLS  
 CRAWFORD COUNTY  
 PROJECT NO. BROS-C024(113)--5F-24

STA. 20+09, EXISTING 88'x18' STEEL PONY THRU-TRUSS BRIDGE WITH STEEL BEAM APPROACH SPAN, TIMBER DECK, STEEL AND TIMBER TRESTLE PILES, AND STEEL AND TIMBER HIGH ABUTMENTS TO BE REMOVED FROM THE PROJECT RIGHT-OF-WAY. CONTRACTOR SHALL CONSTRUCT AT STA. 20+30, TWIN 12'x12'x54' RCB CULVERT, SKEW 45° RT. AHEAD, WITH 45° FLARED WING HEADWALLS.  
 D.A. = 7.11 SQ. MI.

① NE1/4 NW1/4  
 16-83-41

SITUATION PLAN

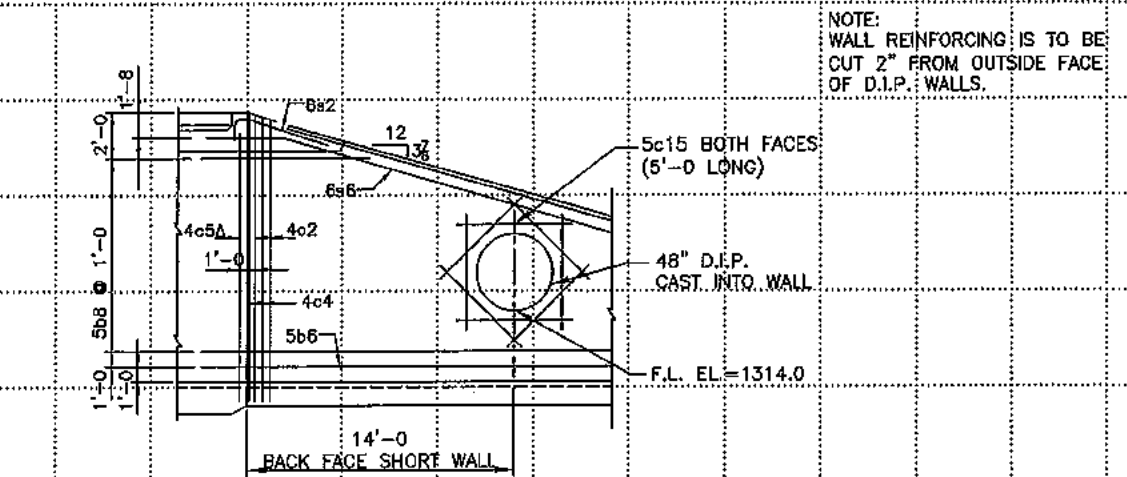
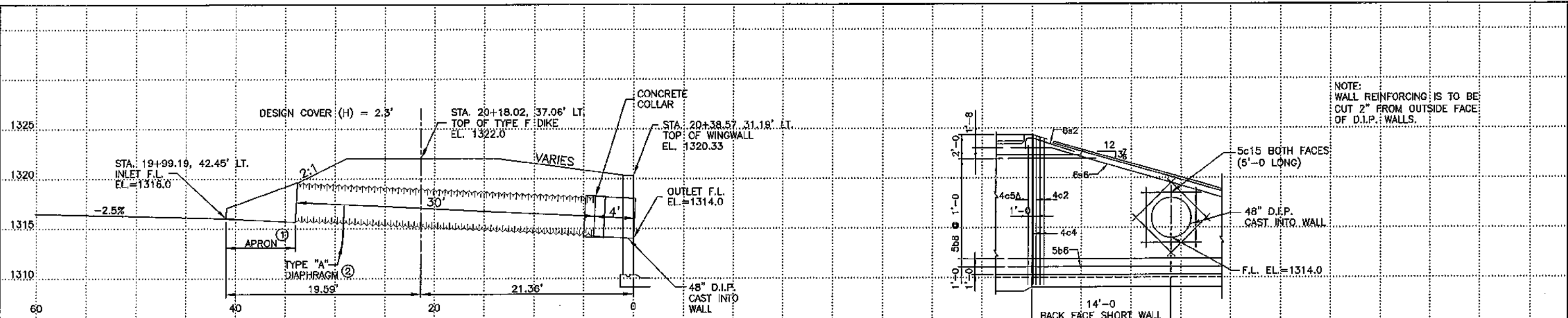

CONNECT D.I.P. TO C.M.P. PER SUPPLIER RECOMMENDATION (PROVIDE CONCRETE COLLAR)

- NOTES:
- STANDARD: TYPE JOINT COUPLINGS ARE REQUIRED. (SEE MATERIALS I.M. 441.)
- ① SEE STANDARD: ROAD PLAN DR-203.
- ② SEE STANDARD: ROAD PLAN DR-501.

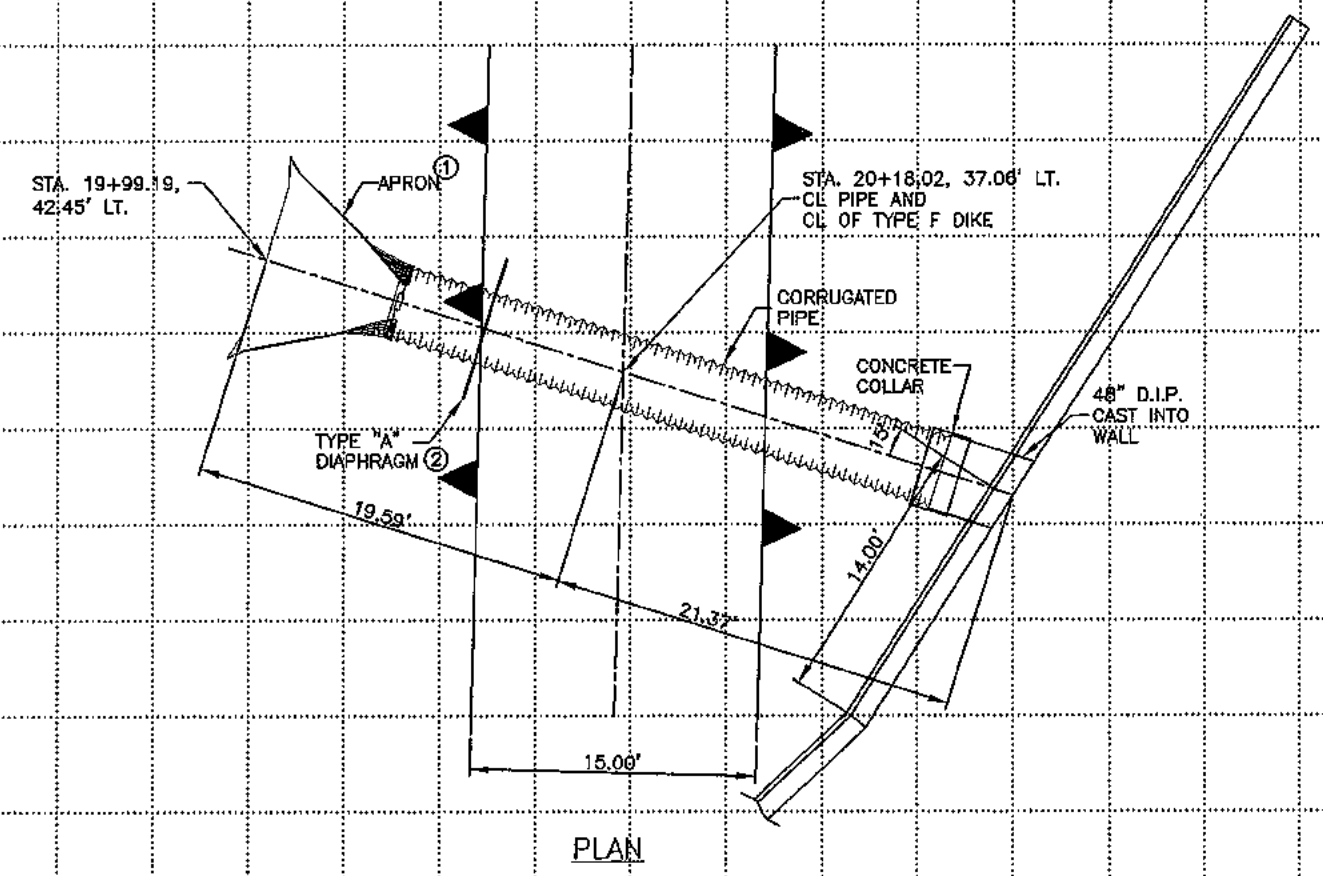

CORRUGATED PIPE LETDOWN STRUCTURE

